

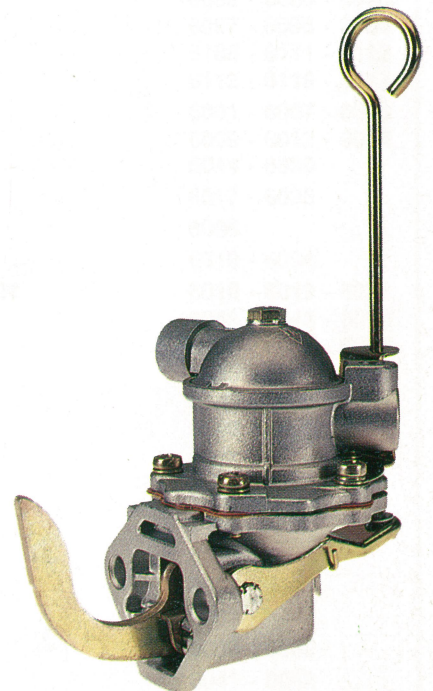

POMPE ALIMENTAZIONE DIESEL
DIESEL LIFT PUMPS
POMPES D'ALIMENTATION GAZOLE
DIESEL PUMPEN

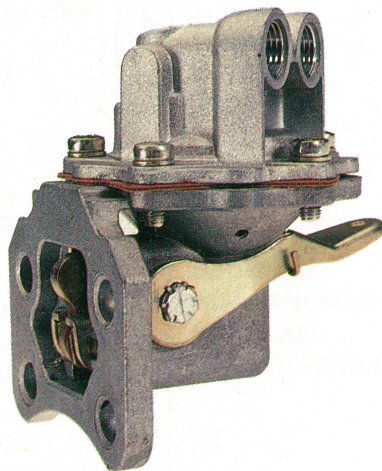
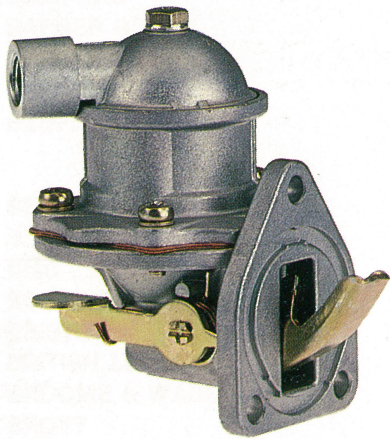

PIENNE s.r.l.

Via Cristalliera, 21 - 10139 TORINO (ITALIA)

Tel. (011) 761613/761495

Telex 225537 PIENNE I

Riferimenti PN/Marche costruttori
PN Ref. to Manufacturers Makes
References PN/Marques fabricants

Costruttore	Ns. Rifer.
AEC	6065 - 6500
ALBION	6018 - 6500
ALFA ROMEO	6039 - 6052 - 6085
ALLIS CHALMERS	6019 - 6065 - 6067 6501
ALSTHON DIESELAIR	6049
ARONA	6027
ATLAS COPCO	6092
ATKINSON	6081
AUSTIN	6037 - 6070 - 6073 6102
AVELING BARFORD	6016 - 6086 - 6094
AXERIO	6000
BAMFORD	6065
BARBER GREEN	6501
BARREIROS	6020
BEARDMORE	6056
BEDFORD	6018 - 6019 - 6053 6056 - 6057 - 6062 6082 - 6085 - 6500
BERNARD	6021 - 6022
BERLIET	6110
BMC	6037
BOLINDER MUNKTELL	6057 - 6092 - 6094
BRISTOL	6504
BRITISH LEYLAND	6037 - 6067
BROOME & WADE	6092
BROYT	6086
CARRARO	6000 - 6001
CAV DIESEL INJECTOR	6018 - 6019 - 6065 6500 - 6509
CHAMBERLAIN	6016
CHRYSLER (vedi TALBOT)	
CLARK	6016 - 6067
COLES CRANE	6086 - 6508
COMMER	6034 - 6056 - 6067
COMPAIR	6086
CONSOLIDATED PNEUMATIC	6086 - 6092
COVENTRY CLIMAX	6057 - 6086
DALE ELECTRIC	6086 - 6092
DAVID BROWN	6024
DODGE	6065 - 6067 - 6500
DOUGLAS	6067
DRONNINGBORG	6086
EICHER HIDROVANE COMPRESSORS	6092
ERON	6028
FERRARI	6001 - 6007
F.I.A.T.	6002 - 6003 - 6004 6005 - 6006 - 6031 6039 - 6091
FORD	6017 - 6018 - 6019 6023 - 6025 - 6036 6056 - 6057 - 6500 6502 - 6508
FISPA	6032
GOLDONI	6001 - 6007 - 6008
HAULAMATIC	6503
HESTAIR DENNIS	6086

Costruttore	Ns. Rifer.
HY-MAC	6086
HYDROMATIC	6086
HURLIMANN	6093
IMSA	6076 - 6091
INTERNATIONAL HARVESTER	6016 - 6019 - 6067 6072 - 6502
INGERSOLL RAND	6092
ITMA	6033
J.C.B.	6086
JEFFERIERS	6057
JOHN DEER	6074
JOHNSTON BROS	6092
KARRIER	6034
KHD (DEUTZ)	6103
LAMBORGHINI	6033 - 6045 - 6093
LANCER BOSS	6086
LANDINI	6010 - 6011 - 6048 6084 - 6086 - 6092 6094
LAND ROVER	6075 - 6078 - 6089
LAVERDA	6086
LEYLAND COMMERCIAL	6086 - 6092 - 6500 6503 - 6504 - 6509 6510
LINDNER	6092
LISTER	6059 - 6060 - 6096 6097 - 6098 - 6104 6105 - 6111 - 6112 6113 - 6116 - 6117
LOMBARDINI	6001 - 6007 - 6008 6009 - 6012 - 6013 6044 - 6090
LOTUS CAR	6017 - 6035
M.F. HANOMAG	6086
MARSHALL	6016 - 6094
MASSEY FERGUSON	6016 - 6019 - 6034 6046 - 6048 - 6050 6056 - 6058 - 6061 6065 - 6067 - 6084 6086 - 6092 - 6094 6100 - 6501
MORGAN	6017
MORRIS	6037
MOSKVITCH	6085
MUIRHILL	6086
NUFFIELD	6037
OLIVER	6067
OM (IVECO)	6006 - 6039
OPEL	6041 - 6082
PERKINS	6016 - 6019 - 6034 6046 - 6047 - 6048 6049 - 6050 - 6051 6056 - 6057 - 6058 6061 - 6062 - 6063 6064 - 6065 - 6067 6076 - 6077 - 6081 6083 - 6085 - 6086 6087 - 6092 - 6094 6100 - 6501 - 6503 6505 - 6506 - 6507 6510

Riferimenti PN/Marche costruttori PN Ref. to Manufacturers Makes References PN/Marques fabricants

Costruttore	Ns. Rifer.	Costruttore	Ns. Rifer.
PEUGEOT	6022	SOFIM	6039
RAMSOMERS	6057	SPERRY NEW	6086
ROVER	6075 - 6078 - 6089	STANDARD	6034
SAME	6014 - 6015 - 6029 6033 - 6038 - 6040 6045 - 6093	TALBOT-CHRYSLER	6056 - 6057 - 6065 6067 - 6081 - 6083 6085 - 6086 - 6100 6500 - 6503 - 6505 6510
SANTANA	6078	TOSELLI	6001
SAVIEM	6047 - 6052 - 6095	TROJAN	6019 - 6056
SEDDON ATKINSON	6086	V M	6012 - 6026 - 6066 6068 - 6069
SERNAGIOTTO	6015	VOLVO	6509
SIMMS	6023 - 6025 - 6057 6502	VOLKSWAGEN	6099
SHELVOKE & DREWRY	6504	WEATHERHILL HOLLAND	6086
SLANZI	6012 - 6030 - 6042 6043		
SISU	6504		

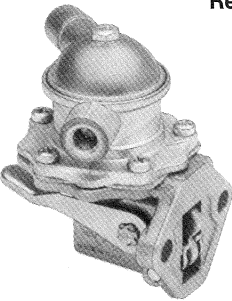
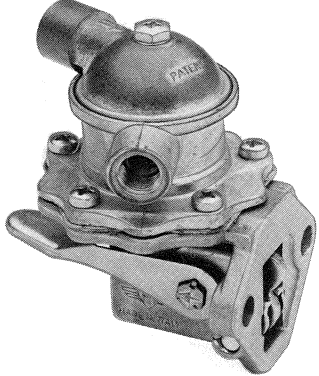
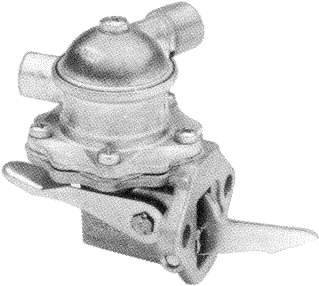
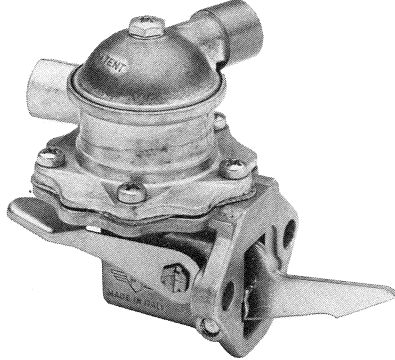
	N. Originale O.E.M.	Applicazione
 <p>Ref. PN 6000</p>	<p>Axerio 100.9443 Carraro 30424</p>	<p>AXERIO Motocompressori A 55 - A 75 Motocompressori A 103 - A 103 B Motocompressori A 103 C - D 32 - dal 1971</p> <p>CARRARO: Trattori con motore 300</p>
 <p>Ref. PN 6001</p>	<p>Lombardini 276.6585.11</p>	<p>CARRARO - Trattori Supertigre 635 con mot. LDA 672 Supertigre 650 con mot. LDA 673 Supertigre 835 con mot. LDA 672 Tigrone 850 con mot. LDA 672 Tigrone 750 - Atlas 750 Tigrone Tropical 750/765 Tigrone Atlas 765</p> <p>FERRARI MC 60 RT con mot. LDA 672 MT 65/30-35 MT 75 con mot. LDA 672 MT 65/30-35 MT 76 con mot. LDA 673</p> <p>GOLDONI Trattore GM4 - L 30 Trattore Universal 230 con mot. LDA 672</p> <p>LOMBARDINI LDA 672 - 673 - 832 - 833</p> <p>Trattori: Bertolini 430 con mot. LDA 672 Bertolini 432 con mot. LDA 672 Bertolini 440/3 C con mot. LDA 673 Bertolini 450/3 C con mot. LDA 673</p> <p>TOSELLI Trattore Euro 30 - Record con mot. Lombardini LDA 672</p>
 <p>Ref. PN 6002</p>	<p>FIAT 4631972 4718363</p>	<p>FIAT Trattori a benzina mot. 8035.42.005 per applicazioni «UNIC France».</p>
 <p>Ref. PN 6003</p>	<p>FIAT 4607671 4607672 4609596 4660069 4667509 4709282 4648022 4740717 4757883</p>	<p>FIAT Trattori serie Nastro d'Oro dal 300 al 550</p> <p>FIAT - OM - Trattori 355 - 400 - 450 - 450 DT - 455 - 455 C compatto - 480 - 480 DT - 500 - 500 DT Special - 550 - 550 DT - 555 - 600 DT - 600 DT 3 - 605 C - 640 DT - 640 compatto (tutti con mot. 8045.01.200)</p> <p>FIAT - OM - Carrelli elevatori DM 12 - DM 15 - DM 12 CD - DM 15 BD - DIM 20 - DIM 25 - DIM 20 CD - DIM 20 CDH - DIM 25 DB - DIM 25 BDH</p> <p>FIAT ALLIS - Macchine movimento terra AD 4 - FL 4 - FL 4 C - FL 4 D - Idrovert TL 5 (tutti con motori 8045.01.200)</p>

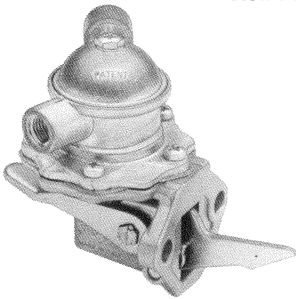
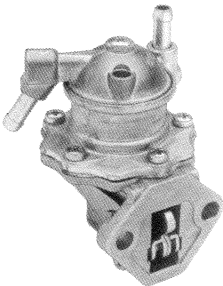
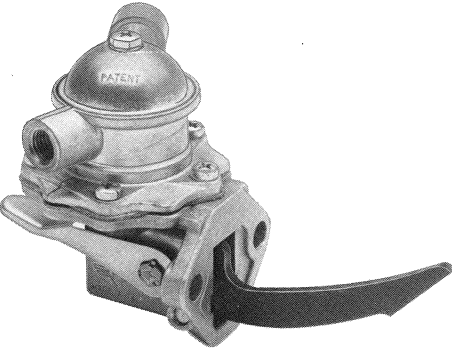
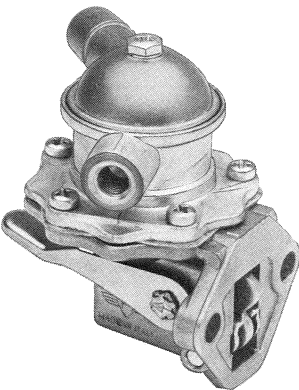
	N. Originale O.E.M.	Applicazione
	Ref. PN 6004 Fiat 4660268 4667510 4709283 Fiat Allis 79023809 4757884	FIAT ALLIS - Macchine movimento terra FL 4 C (con mot. 8035.01.265) pompa iniezione tipo Bosch FL 4 C dal 1971
	Ref. PN 6005 Fiat 1371163	FIAT Torpedo - Campagnola Diesel dal 1968
	Ref. PN 6006 Fiat 4673618 4709284 4757884 4740719	FIAT - OM Autocarro 55 NC - 50 NC - 616 M 3/4 Autocarro OM 35/40 (con mot. 8065.02.300) FIAT - Veicoli Industriali (IVECO) Autocarro 616 N 3/4 Autocarro 50 NC/A-B-C Autocarro 55 MC Autocarro 50/10 - 55/10 Autocarro 40/35 Autocarro 40 - 50/8 FIAT - Trattori (Fiat Allis) Trattori 805 - 880 e derivati OM - Veicoli Industriali (IVECO) Autocarro 40/35 A-B - 40 AB Autocarro 50 A-B-C Autocarro 55 A-B Autocarro 65 A-B-C Autocarro 70 A-B Autocarro 50/8 - 55/8 - 65/10 - 70/10 - 75/10
	Ref. PN 6007 6416.6585.07 283.6585.31	FERRARI Trattore MC 60 RT con mot. Lombardini LDA 96/97 Trattore MC 60 con mot. Lombardini LDA 91/96/97 Motocoltivatori MC 64/68 con mot. Lombardini 71/80 Motocoltivatori 72 con mot. Lombardini 520 Motocoltivatori 72 Super con mot. Lombardini 520 Motofalciatrice 702/703 con mot. Lombardini LDA 80 Motofalciatrice 703/705 con mot. Lombardini LDA 80 GOLDONI Motocoltivatore Special con mot. Lombardini LDA 80/451 Motocoltivatore Export con mot. Lombardini LDA 91/97 LOMBARDINI Motori LDA 80 e derivati Motori LDA 80/b e derivati Motori LDA 96 e derivati Motori serie 500 - 503 - 505 - 507 - 520 - 523 - 525 - 527 Motori LDA 450 (gruppo 3-4)

Le ns. pompe non sono originali, ma con queste perfettamente intercambiabili. I numeri di riferimento originali hanno semplice valore indicativo.

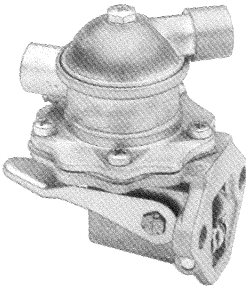
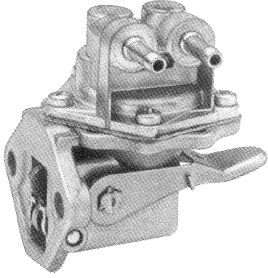
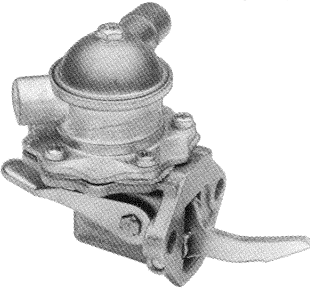
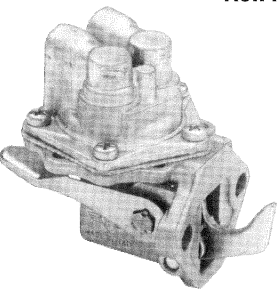
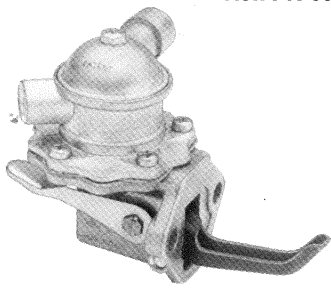
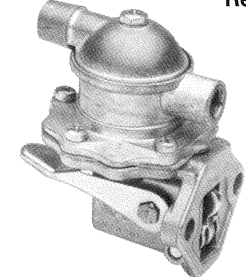
	N. Originale O.E.M.	Applicazione
	Ref. PN 6008 6416.6585.13	GOLDONI Motocoltivatori a benzina (questa pompa è stata sostituita dalla 6009 dal maggio 1975, siano motori con o senza i motorini di avviamento) LOMBARDINI Motori senza motorino di avviamento (fino aprile '75) tipo LA 400/490
	Ref. PN 6009 6416.6585.25 6416.6585.26	LOMBARDINI Motori LA 400 - LA 490 e derivati (dal 4/75) con o senza motorini di avviamento
	Ref. PN 6010 Fispa 401310	LANDINI 4000 Trattore con pompa iniezione SPICA
	Ref. PN 6011 Fispa 403203 Spica 976043	LANDINI Trattore 4000 con pompa iniezione SPICA Mignon
	Ref. PN 6012 Fispa 401617 501521 VM 1518004 3.518.001	LOMBARDINI Super SLANZI DVA 1000 VM Motori SU 104 - 106 - 954 - 956 dal '65
	Ref. PN 6013 904.65.85.22	LOMBARDINI Motore serie 904

Le ns. pompe non sono originali, ma con queste perfettamente intercambiabili. I numeri di riferimento originali hanno semplice valore indicativo.

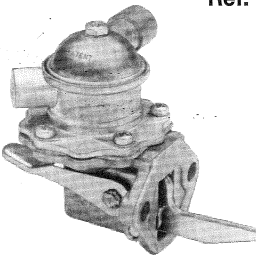
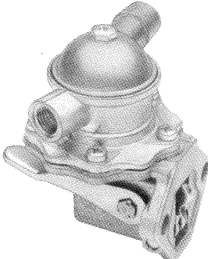
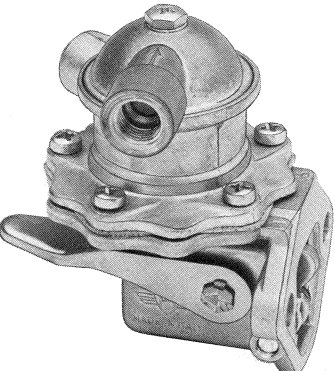
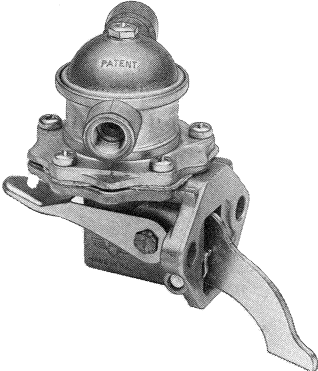
	N. Originale O.E.M.	Applicazione
	Ref. PN 6014 Same 2.4519.010.0	SAME Trattori sino al 1970 (differisce dalla pompa 6040 per la filettatura dei raccordi)
	Ref. PN 6015 Same 2.45.19.120.0 2.45.19.150.0	SAME Trattori Minitauro/Drago 100 - Motore 986 L - Aurora SERNAGIOTTO Motore Renault
	Ref. PN 6016 AC-UF 7950325 7950783 Perkins 2641362	AVELING BARFORD Dumper (Perkins SA 4) '58/'59 Road Roller (Perkins GD 4) '55/'59 CHAMBERLAIN Champion Tractor (Perkins 4/270 TA) CLARK EQUIPMENT Serie 60 Fork Truck (Perkins 4/270) INTERNATIONAL HARVESTER B 450 Tractor (Perkins 4/270) MARSHALL TPJ Road Roller (Perkins 4/203) Trackmarshall (Perkins 4/270) MASSEY FERGUSON Model 685 Combine (Perkins 4A/270) dal '63 Model 780 Combine (Perkins L4/TA) '59 Model 780 Combine (Perkins 4A/270) '58/'63 Model 788 Combine (Perkins 4A/270) dal '63 PERKINS GDA Aveling Barford Road Roller '55/'59 L4TA Massey Ferguson 780 Combine '59 SA4 Aveling Barford Dumper '58/'59 4/270 Cockshutt 560 Tractor 4/270 International Harvester B 450 Tractor 4/270 Massey Ferguson 780/788 Combine '58/'63 4/270 Massey Ferguson 685/780/788 Combine dal '63
	Ref. PN 6017 AC-FG 7971280 7950695 7971263 7950776 7971241 Ford 109 E 9350 B	FORD (Thames) Trucks & Vans 5,7 cwt ('61/'65) FORD CARS New Anglia - Capri - Cortina - Corsair FORD INDUSTRIAL ENGINES Kent Marine LOTUS CARS Mot. Ford 105 E - Seven II° - Super Seven 109 E - Elan 1558 cc. - Elite ('63/'64) MORGAN 65 4/4 serie III - IV - V 1600 ('60)

Le ns. pompe non sono originali, ma con queste perfettamente intercambiabili. I numeri di riferimento originali hanno semplice valore indicativo.

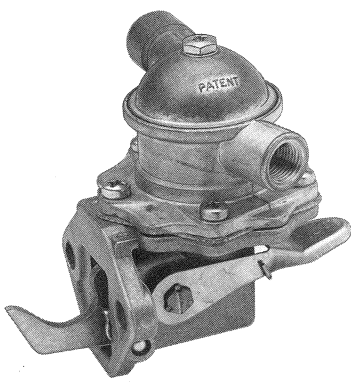
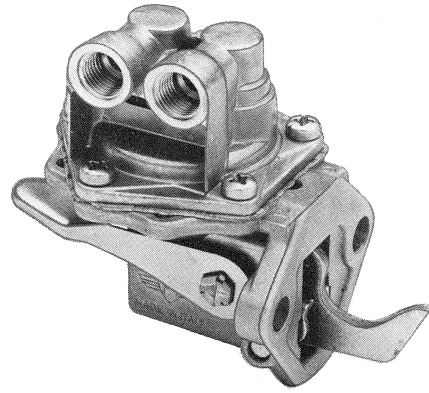
	N. Originale O.E.M.	Applicazione
	Ref. PN 6018 AC-YD 7971051 7950188 7950065 Ford 502 E 9350	ALBION Nimbus EN 250 ('60) BEDFORD TD Truck (200/220 CU in Diesel) TJ Truck (Eng. 45774 - 200/220 CU in Diesel) CAV DIESEL INJECTOR Bedford TD e TJ (Eng. 45774 - 200/220 CU) ('58/'65) International Harvester BMD 6 e TTD 6 Tractors FORD COMMERCIAL Thames Trade (4 cyl. Diesel) '57/'65 2/3 Ton. (4 cyl. Diesel) '54/'57 FORD INDUSTRIAL ENGINES 4 Cyl. c/eq. Simms P4145 - P4178 - P4193 6 Cyl. c/eq. Simms P4316 FORD TRACTORS Major - Super Major (con Exhauster) '54/'62
	Ref. PN 6019 AC-YJ 7950308 7950427 Perkins 30485 35275 36205 Ford 957 E 9350 B Simms 24797 A 461.110	ALLIS CHALMERS Combines (Perkins P3/144) B 272 Tractor (Perkins 3B/152) '57/'60 BEDFORD TJ Truck (Eng. 45775 200/220 CU in Diesel) TK Truck (200/220 CU in Diesel) BEDFORD INDUSTRIAL ENGINES B 7B (200 CU in Diesel) '60/'67 B 10 (220 CU in Diesel) CAV DIESEL INJECTORS Perkins P/3144 Engine FORD TRACTORS Dexta Ligt '57/'62 INTERNATIONAL HARVESTER BC 264 Petrol Engine B 275 Tractor (3B/152) MASSEY FERGUSON Model TE 20 Tractor (Perkins P3/144) '57 PERKINS F3 (Simms in. P4609) P3 Hispania (Simms in. P4588 - P4442 - P4696) P3 TA Trojan 20 cwt '56/'57 P3 TA Trojan 25 cwt (Ch. 8845) '59/'60 P3/144 Ind. British Hoist Crane (Floating) '58 P3/144 Ind. Ford Dexta Tractor (Simms in. P4180) '59/'62 3B/152 Allis Chalmers B 272 Tractor '57/'60 3B/152 International Harvester B 275 Tractor 4/99 Morris Oxford II '58/'59 P3/144 Allis Chalmers Combine Harvester P3/144 Fordson Dexta Tractors '57/'59 P3/144 TA Allis Chalmers B e D 272 Tractors P3/144 TA Bristol Tractor 22 P3/144 Massey Ferguson TE 20 Tractor TROJAN 20 cwt (Perkins P3) '56/'57 25 cwt (Ch. 8845 Perkins P3) '57/'60

Le ns. pompe non sono originali, ma con queste perfettamente intercambiabili. I numeri di riferimento originali hanno semplice valore indicativo.

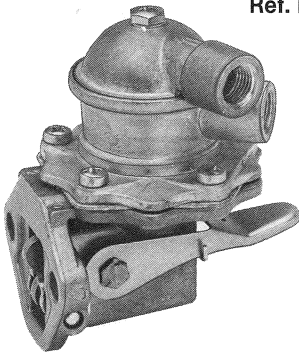
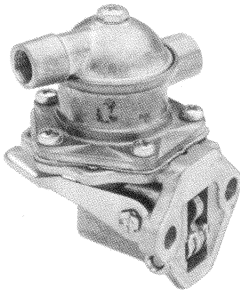
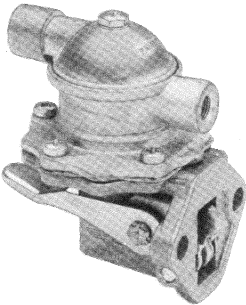
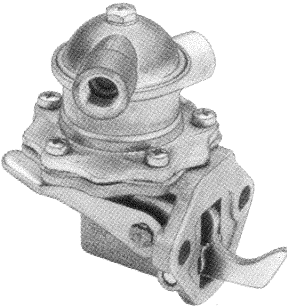
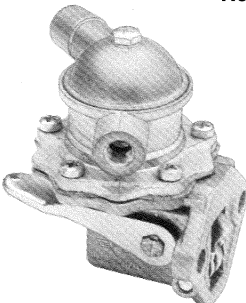
	N. Originale O.E.M.	Applicazione
 Ref. PN 6020	Barreiros 4011072332/A 4011431820	BARREIROS Motore C 60 - Campagnola Diesel mot. C60
 Ref. PN 6021	Sev 85530	BERNARD Moteurs Diesel 32
 Ref. PN 6022	Sev 206.06502.46 CN	BERNARD Moteurs Diesel 32 dal 1970 PEUGEOT 404 Diesel versione Berlina e Taxi dal 12/70
 Ref. PN 6023	AC-YD 7950426 Ford 590 E 9350 Simms 24696 24796 461.109	FORD COMMERCIAL Thames Trader (6 cyl. Diesel) '60/'65 FORD INDUSTRIAL ENGINES 4 cyl. con Simms units P4145 - P4178 - P4250 - P4251 - P4347 - P4348 6 cyl. con Simms units P4316 - P4354 80 hp con Simms units P4354 SIMMS Units P4250 - P4347 - P4251 - P4348 - P4145 - P4178 Units P429 Chaseside e P4235 - P4140 - P4540 - Truck P4130 - P4193 - P4563 Ford 6 cyl. (others) Using In. Units P4067 - Tr. e P4541 Truck Morris 4 cyl. P4273 - Albion Claymore 4 cyl. Engine P4371 Banford Claeyes M 103 Combine (Ford 80 HP Engine) unit P4354
 Ref. PN 6024	AC-FH 7950477 David Brown C902135 461.148	DAVID BROWN 850 Diesel dal '54/'64 850 4 cyl. Diesel '62/'64 950 Diesel dal '60/'62 990 Diesel dal '61/'64

Le ns. pompe non sono originali, ma con queste perfettamente intercambiabili. I numeri di riferimento originali hanno semplice valore indicativo.

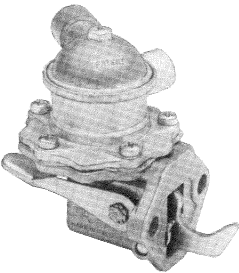
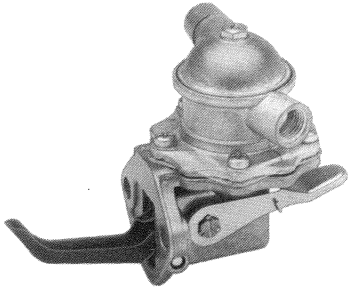
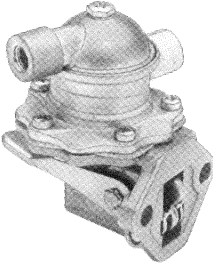
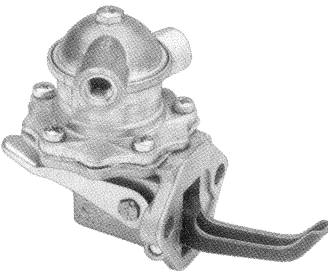
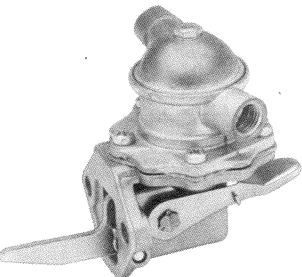
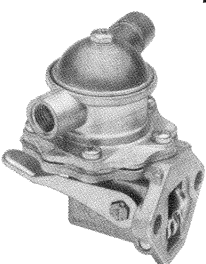
	N. Originale O.E.M.	Applicazione
 Ref. PN 6025	AC-YD 7990020 Simms A 505117/2 461.233 715 F 9350 AA	FORD COMMERCIAL Transit Van (Ford 2/4 Diesel) 6 cyl. Higt Speed Diesel dal '72 SIMMS Ford «York» dal '69 Intercambiabile con pompa originale la cui flangia porta il numero 0020
 Ref. PN 6026	VM 3.518.001	VM Motori serie SL 100
 Ref. PN 6027	Arona 19064	ARONA Motori marini serie C.295 LL
 Ref. PN 6028		ERON
 Ref. PN 6029	Same 2.4519.090.0	SAME
 Ref. PN 6030	Slanzi 405036 405039 Sav 6012/220 9.06.061.00	SLANZI Motori DVA 700 - 920 - 1030

Le ns. pompe non sono originali, ma con queste perfettamente intercambiabili. I numeri di riferimento originali hanno semplice valore indicativo.

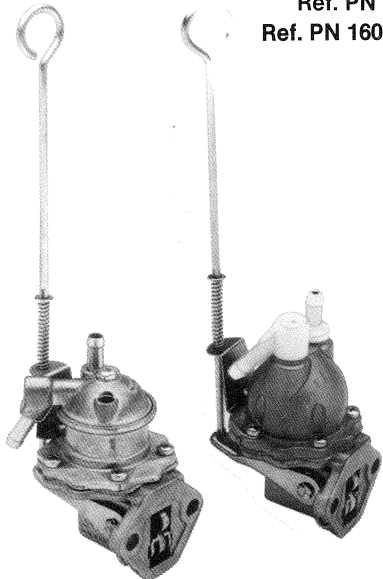
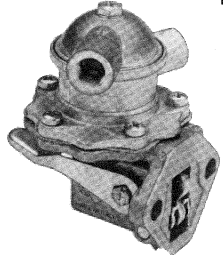
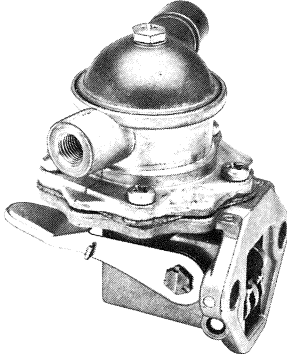
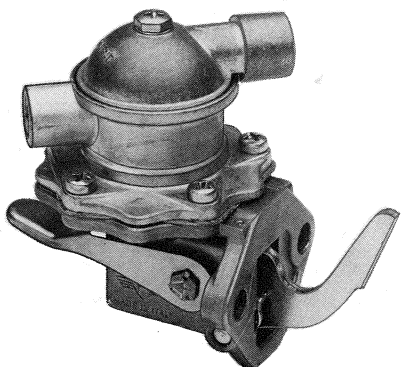
	N. Originale O.E.M.	Applicazione
 <p>Ref. PN 6031 Ref. PN 16031/R</p>	<p>Fiat 4644126 4667668 4718364</p>	<p>FIAT Camioncino e Furgone 1100 TN 1 - Diesel 241 AT - 241 F - 241 M-F - 241 N - 241 TM (con motore 237 A.000) '73</p>
 <p>Ref. PN 6032</p>	<p>Fispa 4015.22</p>	
 <p>Ref. PN 6033</p>	<p>Same 2.4519.160.0 2.4519.100.0 2.4519.190.0</p>	<p>ITMA Trattore A 352 con mot. Same 982L 2 cil. 34 HP - dal '78 Trattore A 503 con mot. Same 983L 3 cil. 53 HP - dal '78</p> <p>LAMBORGHINI Trattore R 235 con mot. Same 982L 2 cil. 34 HP Trattore C 553 con mot. Same 983L 3 cil. 53 HP Trattore C 653 con mot. Same 1053L 3 cil. 62 HP Trattore R 654 con mot. Same 984P 4 cil. 67 HP Trattore R 854 con mot. Same 1054P 4 cil. 82 HP - dal 1978</p> <p>SAME Trattore Sirenetta con mot. 982L 2 cil. 30 HP Trattore Delfino con mot. 982L 2 cil. 34 HP Trattore Aurora con mot. 983L 3 cil. 45 HP Trattore Falcone e Falcon C con mot. 983L 3 cil. 50 HP Trattore Minitauro e Minitauro C con mot. 1053L 3 cil. 60 HP Trattore Corsaro con mot. 984L 4 cil. 67 HP Trattore Saturno con mot. 1054L 4 cil. 78 HP Motori Industriali tipo 982L - 983L - 984L - 1053L - 1054L dal 1978</p>
 <p>Ref. PN 6034</p>	<p>AC-YD 7950073 7950182 7950101 7950186</p> <p>Standard 200292 - 203255</p> <p>Karrier P45899</p> <p>M. Ferguson 826.154.M91</p>	<p>COMMER MK V 15 - 20 - 25 - 30 cwt (Diesel) '56/'63</p> <p>KARRIER Bantam MK V (Light Diesel) '56/'58</p> <p>MASSEY FERGUSON Diesel '54/'55 FE 35 Tractor (Perkins 23 C Diesel) fino mot. SJ37181E '56/'57 Model 20 Tractor (Diesel) '56/'57</p> <p>PERKINS Z3C - Massey Ferguson FE 35 Tr. fino mot. SJ37181E '56/'57</p> <p>STANDARD London Taxi '55/'56 - Vanguard Diesel '54/'67 12 cwt Delivery Van e Pik-up Diesel '60</p>

Le ns. pompe non sono originali, ma con queste perfettamente intercambiabili. I numeri di riferimento originali hanno semplice valore indicativo.

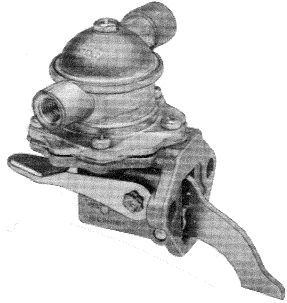
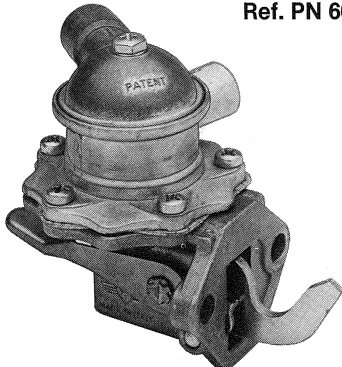
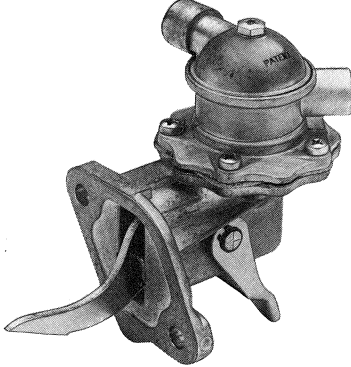
	N. Originale O.E.M.	Applicazione
 <p>Ref. PN 6035</p>	<p>AC-FG 7950776</p>	<p>LOTUS Cars: Elite ('63/'64)</p>
 <p>Ref. PN 6036</p>	<p>AC-YD 7990395 CAV 509943 508267 506401/2 461.279</p>	<p>FORD Furgoni Transit con equipaggiamento CAV dal 1973</p> <p>FORD COMMERCIAL Serie York Diesel dal '73 Transit Van (2400 Ford) dal maggio '72</p> <p>(Questa pompa è adattabile solo per pompe che hanno il numero 0395 sotto la flangia)</p>
 <p>Ref. PN 6037</p>	<p>AC-U 7950300 7950773 7971072 7971073</p> <p>Austin 7 H 1958 BMK 943 946 1051 785 461.170 461.171</p>	<p>AUSTIN Trucks and coaches: FFK 3,8 5,1 5,7 FGK ('64/'71)</p> <p>BMC Marine & Industrial Commodore 3/4 l.</p> <p>BMC TRUCKS FGK 40 - FGK 30 - WEK 30/60/120 FGK 60/80/100</p> <p>BRITISH LEYLAND COMMERCIAL FFK 100 (504) 5 Ton. Diesel '61/'65 FFK 140 (702) 7 Ton. Diesel '61/'65 FFK 240 (504) 12 Ton. Diesel '61/'65 FFK 300 (504) 15 Ton. Diesel '61/'65 FFK 340 17 Ton. Diesel '61/'65 FFK 360 18 Ton. Diesel '61/'65 FGK 30 (S 200) 30 cwt Diesel '61/'65 FGK 40 (T 200) 2 Ton. Diesel '61/'65 FGK 60 (304) 3 Ton. Diesel '61/'65 FGK 80 (404) 4 Ton. Diesel '58/'60 FGK 100 5 Ton. Low Loader Diesel '61/'65 WEK 30 S 203 30 cwt Diesel '58/'65 WEK 40 (T 203) 2 Tonn. Diesel '58/'65 WEK 60 (303) 3 Tonn. Diesel '58/'65 WEK 100 (503) 5 Ton. Diesel '58/'65 WEK 120 6 Ton. Diesel '61/'65 WEK 240 (503) 12 Ton. Diesel '61/'65 WEK 300 (503) 15 Ton. Diesel '61/'65 WFK 30 (3-8) Diesel dal '65 WFK 40 (3-8) Diesel dal '65 WFK 60 (3-8) Diesel dal '65 WFK 100 (5,1-5,7 litri) Diesel dal '65</p> <p>BRITISH LEYLAND MARINE e IND. ENGINE Commodore (3-4 litri) Diesel '62/'65</p> <p>MORRIS Commercial Tr. 54D-60</p> <p>NUFFIELD TRACTORS Diesel Models 3/45 - 4/65 dal '68</p>

Le ns. pompe non sono originali, ma con queste perfettamente intercambiabili. I numeri di riferimento originali hanno semplice valore indicativo.

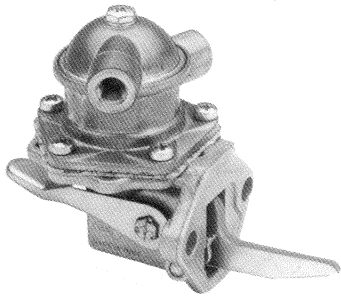
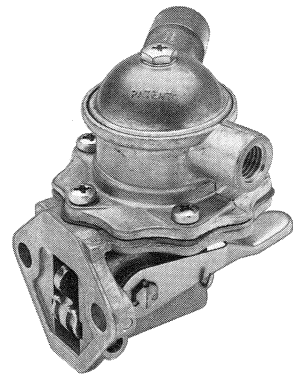
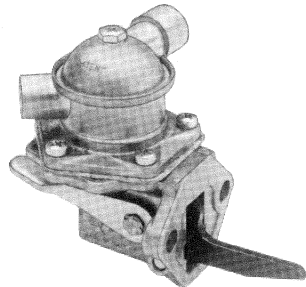
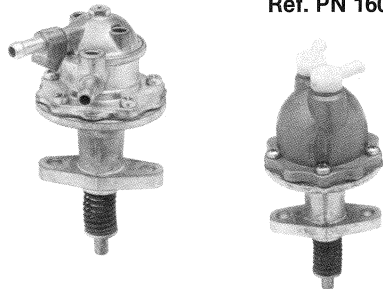
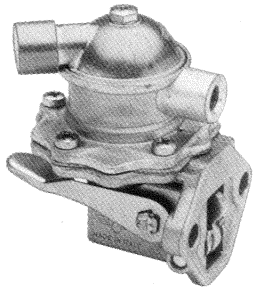
	N. Originale O.E.M.	Applicazione
	Ref. PN 6038 Same 2.4519.010.01 Fispa 4015.07	SAME Centaur 55 e derivati
	Ref. PN 6039 Fiat 4279496 4755893 4740996 4749880 4724652 Sofim 4740996	FIAT AUTO 131 Diesel 2000/2500 mot. Sofim 132 Diesel 2000/2500 mot. Sofim FIAT IVECO - Veicoli Industriali Daily autocarro - furgone - camper - combinato - promiscuo - minibus - scuolabus cabinati con mot. Sofim OM IVECO Grinta autocarro - furgone - camper - combinato - promiscuo - minibus - scuolabus - cabinati con mot. Sofim 30 OM 8 - 32 OM 8 - 35 OM 8 - 40 OM 8 con mot. Sofim SOFIM Motori Diesel tipo 8140.61.300 (4 cil.) e derivati ALFA ROMEO Furgoni - Camioncini serie: AR 8 - 30 AR 8 - 32 AR 8 - 35 AR 8 - 40 AR 8 con mot. Sofim
	Ref. PN 6040 Same 2.4519.130.0	SAME Trattore Centauro - Leone
	Ref. PN 6401 Ref. PN 16041/R APG-PE 15693 Opel 8.160.33 Opel 8.966.487 ACF-PB 3.6943 AC-PB 5506943	OPEL Rekord 2100 D Diesel (2 litri) dal 10/72
	Ref. PN 6042 Slanzi 405030 405037 Savara 6007.33 9.06.019.00	SLANZI Motori DVA 460

Le ns. pompe non sono originali, ma con queste perfettamente intercambiabili. I numeri di riferimento originali hanno semplice valore indicativo.

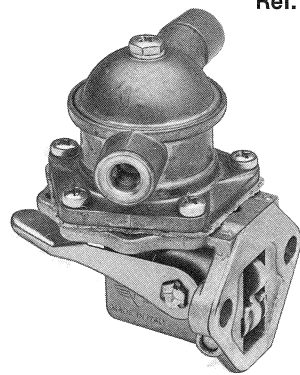
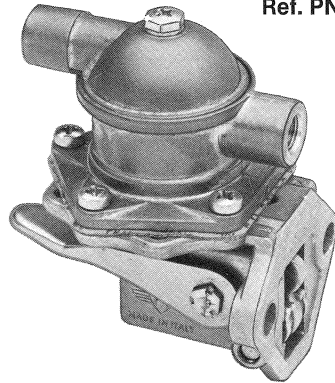
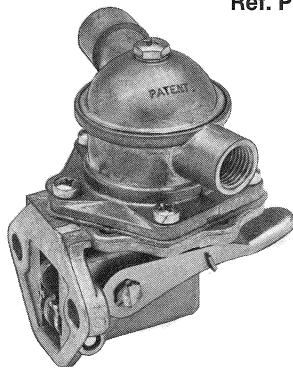
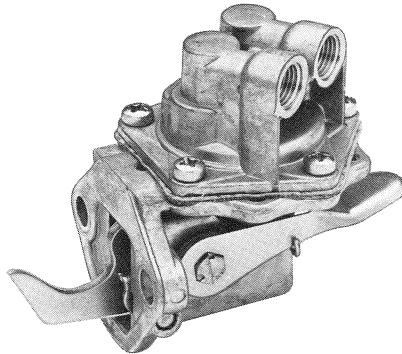
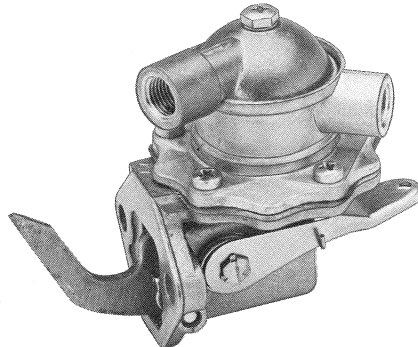
	N. Originale O.E.M.	Applicazione
	Ref. PN 6043 Slanzi 405034 405038 Savara 6012/210 Savara 9.06.060.00	SLANZI Motori DVA 460 - 515
	Ref. PN 6044 Lombardini 6416.6585.27 Fispa 4015.32/A	LOMBARDINI Motori tipo 500 - 520 - 530
	Ref. PN 6045 Same 2.4519.140.0 2.4519.150.0 2.4519.180.0 2.4519.200.0	LAMBORGHINI Trattore R 1056 con mot. 986/P 6 cil. 105 HP dal '78 SAME Trattore Panther 90 con mot. 985 P - 5 cil. - 88 HP - '78 Trattore Tiger 100 con mot. 1055 P - 5 cil. - 102 HP - '78 Trattore Drago 120 con mot. 1056 P - 6 cil. - 115 HP - '78 Trattore Bufalo 130 con mot. 1056 P - 6 cil. - 126 HP - '78
	Ref. PN 6046 AC-YJ 7971233 Perkins 2641311 Massey Ferguson 886.062.M91 461.184	MASSEY FERGUSON DX 35 - DX 40 (Perkins 3 AD/152) HX 210 (Perkins 3 AD/152) MF 135 - MF 150 - MF 203 (Perkins 3 AD/152) MF 2200 - MF 2203 (Perkins 3 AD/152) MF 2205/7 - 135/148 - Tractors Eng. 152 UA 38571 D PERKINS P 2 - 96 3 A/152
	Ref. PN 6047 AC-FH 7971249	PERKINS 597 Saviem SAVIEM SM 6 - SM 7 - SM 8 - S 9/596 6 cyl.

Le ns. pompe non sono originali, ma con queste perfettamente intercambiabili. I numeri di riferimento originali hanno semplice valore indicativo.

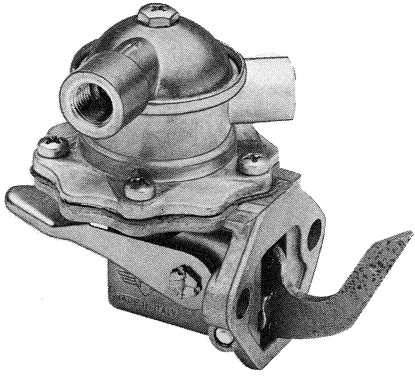
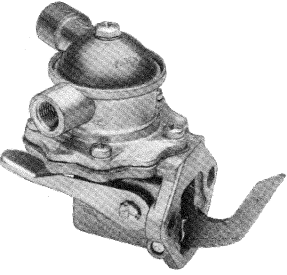
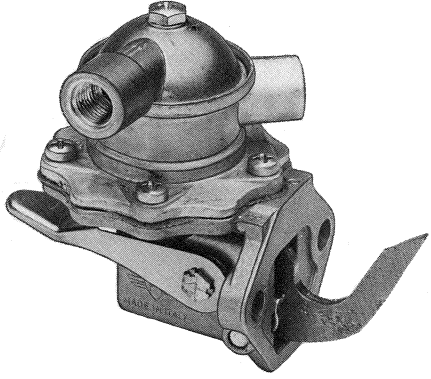
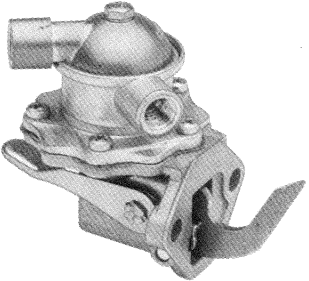
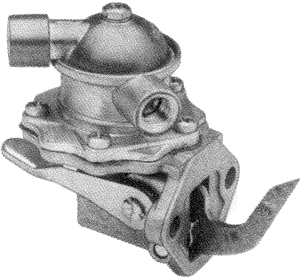
	N. Originale O.E.M.	Applicazione
<p>Ref. PN 6048</p> 	<p>AC-FH 7971116 7971115</p> <p>Perkins 2641328 461.175</p>	<p>LANDINI Trattore 6500 e derivati (con mot. Perkins AD4/203)</p> <p>MASSEY FERGUSON DX 45 (Perkins 4 AD/203) HX 211 (Perkins 4 AD/203 alcuni) MF 165/300 (Perkins 4 AD/203 alcuni) MF 302/304/365/765 (Perkins 4 AD/203 - 4 AD/230 alcuni) MF 3303-3305-3165 S (Perkins 4 AD/203 - 4 AD/230 alcuni) 165 Tractor Combine 3000 dal '66 French HW 21 Tractor dal '66 FE Tractor (Perkins P3/TA)</p> <p>PERKINS A 4/192 Massey Ferguson 65 Tractor MK 1 A D4/203 Massey Ferguson dal '61/'62 P3/TA Massey Ferguson FE 35 - Starter Motor</p>
<p>Ref. PN 6049</p> 	<p>AC-FH 7950839</p> <p>Perkins 2641326</p>	<p>ALSTHOM DIESELAIR 2/3/4/5/6 Cyl. Motore Agrom.</p> <p>PERKINS 4/203 Willys Pick-up dal '64</p>
<p>Ref. PN 6050</p> 	<p>AC-FH 7950621</p> <p>Perkins 35218 32556 AC FH 7950383 461.123</p>	<p>HYSTER Ford Truck H40F (Perkins 4/203) P4/192 Combine Harvester 4/203 Ind. Hunslett Engineering 4/203 TA Fordson 801 Tractor</p> <p>MASSEY FERGUSON FE Tractor (Perkins P3/TA) P3 (Yugoslavia) P3/TA Massey Ferguson FE 35 Tr. P3/TA Massey Ferguson Starter Mot. A/203 - P4/192</p> <p>PERKINS 4/203 TA Fordson 801 Tractor 4/203 Ind. Hunslett Engineering</p>
<p>Ref. PN 6051</p> 	<p>AC-FH 7971320</p> <p>Perkins 2641329 461.205</p>	<p>PERKINS A 4/212 Diversi allestimenti</p>
<p>Ref. PN 6052</p> 	<p>AC-FH 7990084</p> <p>Saviem 50.00.044.183 461.246</p>	<p>ALFA ROMEO Furgone A 19 (con motore Perkins Diesel)</p> <p>SAVIEM SB 2 - SG 2 - SG 4 - SG 5 - SM 5 (712 4 cyl.) - TP 3F (712 4 cyl.) TP 4 (712 4 cyl.)</p>

Le ns. pompe non sono originali, ma con queste perfettamente intercambiabili. I numeri di riferimento originali hanno semplice valore indicativo.

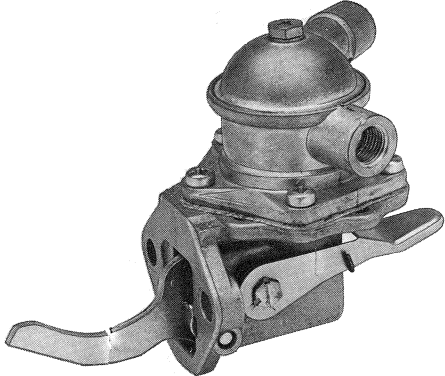
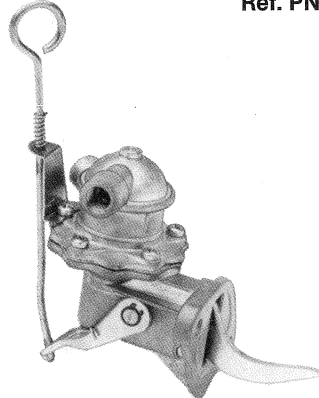
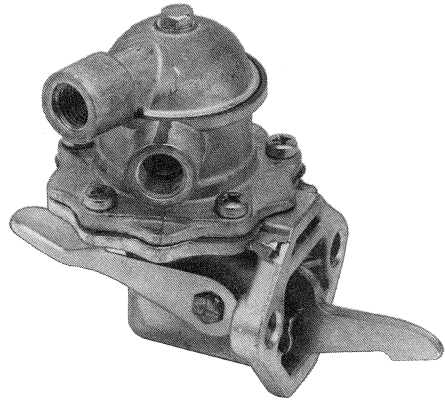
	N. Originale O.E.M.	Applicazione
<p>Ref. PN 6053</p> 	<p>AC-UF 7950500 7971020 461.159 816.038</p>	<p>BEDFORD C Truck (330 cu in Diesel) dal '70 M Truck Diesel P Coach chassis (300-330 cu in Diesel) R Truck (Eng. 54222-67927 Diesel) R Truck (Eng. 67928 Diesel) TJ Truck (Eng. 160220 in poi 300 cu in Diesel) TJ Truck (Eng. 160235 in poi 330 cu in Diesel) VA Coach chassis (300 cu in Diesel) VA Coach chassis (300/330 cu in Diesel) VAS 1 Bus 300 cu in Eng. from chassis 2417 TK Truck (EON - EOM - EOQ - EOR - EOT - EOV - HR X3) 330 cu in Diesel</p>
<p>Ref. PN 6054</p> 	<p>808137 (Spagna)</p>	
<p>Ref. PN 6056</p> 	<p>AC-YJ 7950421</p> <p>Perkins 32567 35567 461.108</p>	<p>BEARDMORE Taxi (Perkins 4/99) '60</p> <p>BEDFORD CA Van Diesel (Perkins 4/99) '61/'65</p> <p>CHRYSLER PA 1500/2500 (Perkins 4/108) '67 PB Van Engine 108 U 13472 (Perkins 4/108) '67</p> <p>COMMER PA 1500/2500 (Perkins 4/108) '65 1500 15 cwt Van (Perkins 4/99) '59/'65 2500 15 cwt Van (Perkins 4/99) '59/'65</p> <p>FORD COMMERCIAL Thames 10 - 12 - 15 cwt - Van e Bus Diesel '61/'65 10 - 12 - 15 cwt - Van pick-up Transporter Diesel</p> <p>MASSEY FERGUSON Model 630 Combine (Perkins A 4/107)</p> <p>PERKINS 4/99 Beardmore Taxi dal '65 4/99 Bedford CA Van '61/'64 4/99 Commer 1500/2000 dal '65 4/99 Ford 10 - 12 - 15 cwt Van '65 4/99 Trojan 25 cwt Bus (dal ch. 8844) '58/'59 A 4/99 Massey Ferguson 31-6 e 830 Combine (Francia) '58/'59 A 4/107 Ford 10 - 12 - 15 cwt Van A 4/107 Massey Ferguson 86/6 e 630 Combine - 4/108 Chrysler '67</p> <p>TROJAN Bus 12 passeggeri (Perkins 4/99) '58/'59</p>

Le ns. pompe non sono originali, ma con queste perfettamente intercambiabili. I numeri di riferimento originali hanno semplice valore indicativo.

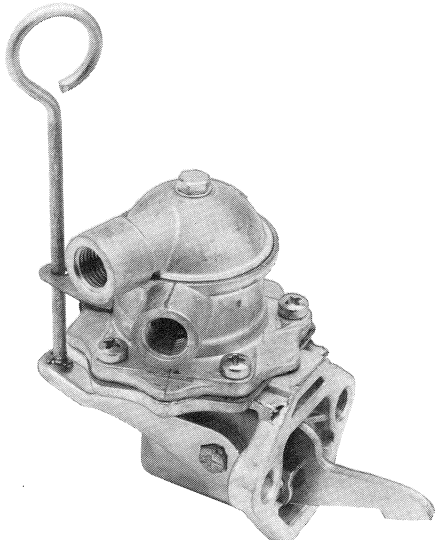
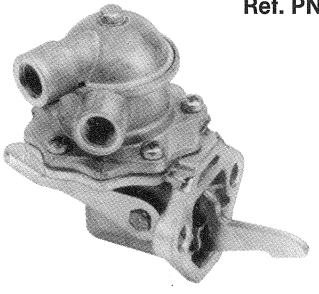
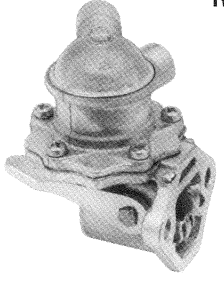
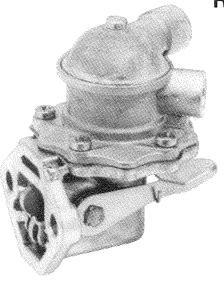
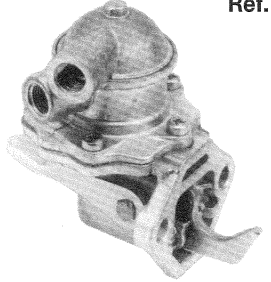
	N. Originale O.E.M.	Applicazione
 <p>Ref. PN 6057</p>	<p>AC-YJ 7971304</p> <p>Perkins 2641314 461.204 6637821</p>	<p>BEDFORD CF Van 14 - 18 - 22 cwt (Perkins 4/108) '69/'73</p> <p>BOLINDER MUNKTELL ST 257 Combine (Perkins 4/108 TA)</p> <p>CHRYSLER PB Van (Perkins 4/108) E (Spagna) PB Engine 108 U 13473 - 108 U 46250 dal '67</p> <p>COVENTRY CLIMAX Fork Truck (Perkins 4/107)</p> <p>FORD COMMERCIAL Transit Van (Perkins Diesel)</p> <p>HYSTER Fork Truck H 20 - 25 E - H 20 - 30 D (Perkins 4/107)</p> <p>PERKINS 4/108 Marine - 4/107</p> <p>RANSOMERS - SIMMS - JEFFERIES Combine (Perkins 4/107 A)</p>
 <p>Ref. PN 6058</p>	<p>AC-YJ 7950607</p> <p>Perkins 2641305</p>	<p>MASSEY FERGUSON Model 130 Tractor (Perkins A 4/107) dal '65</p> <p>PERKINS A 4/99 Massey Ferguson 825 Tractor (Frame) A 4/107 Massey Ferguson CKD A 4/107 Massey Ferguson 130 Tractor</p>
 <p>Ref. PN 6059</p>	<p>AC-YD 7950461</p> <p>Lister 351-12150 B 461.115</p>	<p>LISTER HA - HB - LD - SL (Diesel Air Code)</p>
 <p>Ref. PN 6060</p>	<p>AC-YD 7990046</p> <p>Lister 351-12150 461.240</p>	<p>LISTER SR 2 - 3 - 4 Cyl. (Motore Marino)</p>
 <p>Ref. PN 6061</p>	<p>AC-VJ 7971040</p> <p>Perkins 2641310</p> <p>Massey Ferguson 883.770.M91 461.167</p>	<p>MASSEY FERGUSON 135 Tractor</p> <p>PERKINS 3/152 dal '66</p>

Le ns. pompe non sono originali, ma con queste perfettamente intercambiabili. I numeri di riferimento originali hanno semplice valore indicativo.

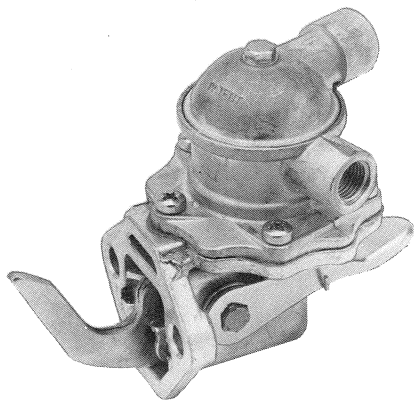
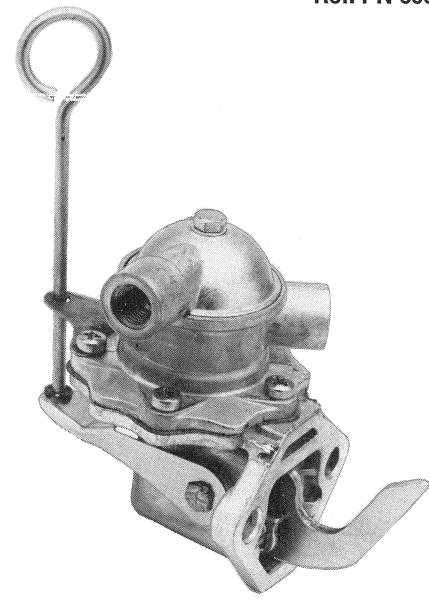
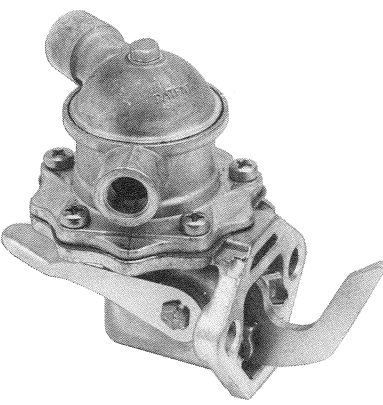
	N. Originale O.E.M.	Applicazione
 <p>Ref. PN 6062</p>	<p>AC-FH 7950885</p> <p>Perkins 2641327 461.147</p>	<p>BEDFORD CF Van 22 e 35 CW 4/154 cu in Diesel Perkins dal '69</p> <p>PERKINS 4/154</p>
 <p>Ref. PN 6063</p>	<p>AC-HF 7971262</p> <p>Perkins 2641333 461.193</p>	<p>PERKINS Motore A 4/318</p>
 <p>Ref. PN 6064</p>	<p>AC-HF 7990015</p> <p>Perkins 2641334</p>	<p>PERKINS 4/203 V</p>

Le ns. pompe non sono originali, ma con queste perfettamente intercambiabili. I numeri di riferimento originali hanno semplice valore indicativo.

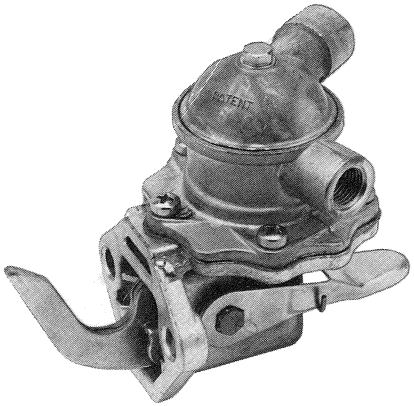
	N. Originale O.E.M.	Applicazione
	Ref. PN 6065 AC-UF 7950770 7950499 Perkins 2641363 2641371 Dodge D2 8692 D3 34265 AEC 78-997 461.116 461.137	AEC AVU 470 E Engine AV 275 - 312 - 319 Engine AV 470 E - 590 Engine (DPA units) AV 505 Engine (LHD) '63/'66 Mammoth e Mammoth Major (DPA units) Mercury (CAV inj.) Reliance Express Coach ZAV 690/5 B x Engine 410 Engine (DPA units) ALLIS CHALMERS A. Combine (Perkins 6/288) C. Combine (Perkins 6/305) '63 BTL 12 D - 14 D - 16 D - 20 D Tractor Loader (DPA units) '63 BAMFORD JCB 6 - 7 - 7 C - 8 Escavatore (Perkins 6/354) CAV DIESEL INJECTOR AEC (Dodge Trucks) AEC Mammoth Major (DPA units) '63/'65 AEC Mercury (DPA units) '63/'65 CHRYSLER D 405 - 406 FC 3,5 - 5 - 6 - 7 Ton. DODGE D 309 9,5 - 11 - 13 - 14 Ton. (AEC 410) '64/'65 D 310 (AEC 470) '64/'65 D 405 - D 406 (Perkins 6/305) '64/'70 R 308 - T 308 9,5 - 10 - 11 - 12 - 14 Ton. (AEC 410) '64/'65 R 310 - T 310 (AEC 410) '64/'65 3 Ton. N/C (Perkins 6/305) '61/'64 3,5 Ton. F/C - 5 Ton. N/C - F/C (Perkins 6/305) '61 6 Ton. N/C - F/C (Perkins 6/305) '61/'64 6 Ton. F/C (Perkins 6/305) '61/'64 6 Ton. F/C (Perkins 6/305) '61 7 Ton. F/C (AEC 410) '61 9,5 Ton. - 10 Ton. F/C (AEC 410) '64/'65 11 Ton. - 12 Ton. - 14 Ton. F/C (AEC 410) '64/'65 HYSTER Fork Truck HB 100 - H 100 C (Perkins 6/305) Fork Truck RC 150 (Perkins 6/350) MASSEY FERGUSON Tx 37 Combine e Super 90 Tractor (Perkins A 4/300) PERKINS 4/99 - Marine 4/A300 Massey Ferguson Tx 37 Comb. e Super 90 Tr. fino al '61 6/288 Allis Chalmers A Combine '61 P6 CAV inj. pump '58/'64 6/288 Allis Chalmers A Combine '65 6/305 Allis Chalmers C Combine '65 6/305 Ind. Hyster HB 100 Fork-lift-truck '65 6/305 Ind. Hyster H 100 C Fork-lift-truck 6/340 Combine '65
	Ref. PN 6066 VM 8.500.121 1.518.003 1.518.006 1.518.010	VM Motori serie 102/103 SU versione trattore Motori serie 952/953 SU - 104 SU/T - 104 SU a 2 - 3 - 4 cyl.

Le ns. pompe non sono originali, ma con queste perfettamente intercambiabili. I numeri di riferimento originali hanno semplice valore indicativo.

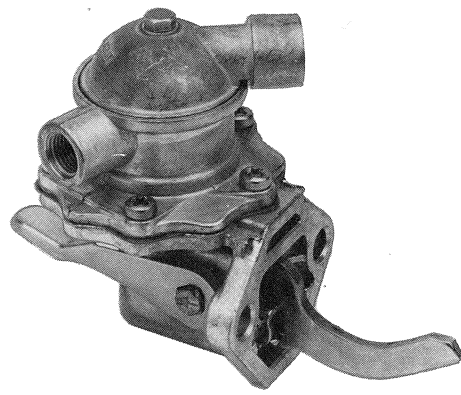
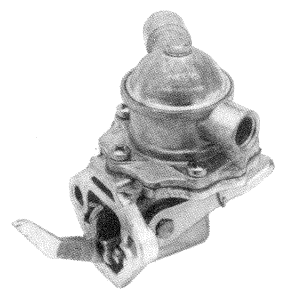
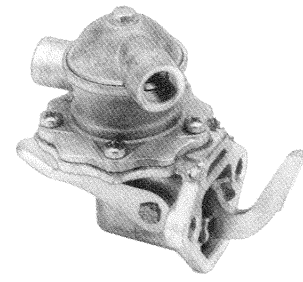
	N. Originale O.E.M.	Applicazione
	Ref. PN 6067 AC-UF 7950766 7950598 7950768 Perkins 2641312 2641372 Commer 5039053 5042263 461.133	ALLIS CHALMERS TL 545 Tract. Loader (Perkins 6/354) 4000 Combine BRITISH LEYLAND Boxer (Perkins 6/354) '72 CHRYSLER B Truck 2 - 3 - 4 - 5 - 6 Ton. Bus Heavy Bus Light D 500 FC 6 - 7 - 8 - 9,5 - 10 - 11 - 12 Ton. (tutti con mot. Perkins 6/354) '65 CLARK EQUIPMENT Fork Truck Perkins 6/354 COMMER B Truck 2 - 3 - 4 - 5 - 6 Ton. (Perkins 6/354) '60/'64 B Truck 2 - 3 - 4 - 5 - 6 Ton. (Perkins 6/354) '64 DODGE Bus Heavy e Bus Light D 500 8 Ton. F/C - 9,5 Ton. F/C 10 - 11 - 12 Ton. F/C 6 Ton. N/C - 7 Ton. F/C - N/C (escluso D 406 - 407) 6 Ton. F/C tutti con mot. Perkins 6/354 DOUGLAS Tugmaster (Perkins 6/354) HISTER Fork Truck H 150 e H 250 Stradale Carrier M 300 tutti con mot. 6/354 Perkins INTERNATIONAL HARVESTER H 65 Payloader - JH 60 con motore Perkins 6/354 MASSEY FERGUSON Model 500 Combine (Perkins 6 A/354 Diesel) '65 OLIVER (COCKSHUTT) 431 - 432 Combines (Perkins 6/354) PERKINS 6/354 Commer B 2 - 3 - 4 - 5 - 6 Ton. '65 6/354 Dodge 6 - 7 Ton. N/C '61/'64 6/354 Dodge 6 - 7 - 8 - 9,5 - 10 - 12 Ton. F/C dal '65 6/354 International Harvester C 1600 - C 1800 - 1600 - 1800 Loadster Truck '65
	Ref. PN 6068 	VM 1.518.009 1.518.007 8.500.128
	Ref. PN 6069 VM 1.518.014 1.518.015	VM Motore HR 488 - 588 - 688 H - 688 HT

Le ns. pompe non sono originali, ma con queste perfettamente intercambiabili. I numeri di riferimento originali hanno semplice valore indicativo.

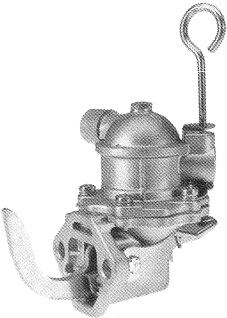
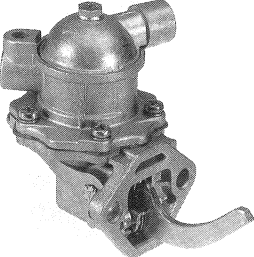
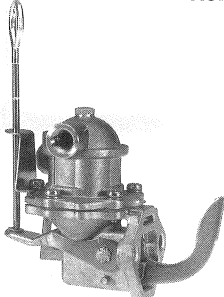
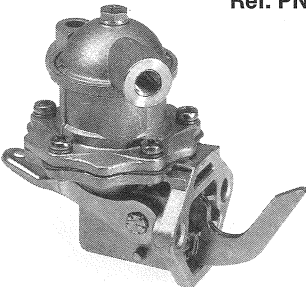
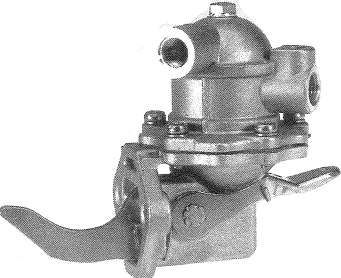
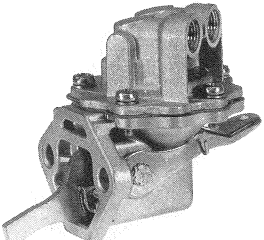
	N. Originale O.E.M.	Applicazione
 Ref. PN 6070	AC-UF 7950622 Austin 12 H 180 12 H 195	AUSTIN A 60 Cambridge (1-5 L - Diesel '62/'65) BRITISH LEYLAND COMMERCIAL J 2 Van - Diesel '60/'66 152 Truck - Coach - Omnivar '58/'65 SAVA (Spagna) J 004 (allestimenti diversi)
 Ref. PN 6072	461-114 7950454 708294/R93	INTERNATIONAL HARVESTER BD 144 Diesel Eng. BD 154 Diesel Eng. B 275 Tractor - Diesel B 414 Tractor B 434 Tractor - Diesel B 450 Wheel Tractor
 Ref. PN 6073	XP 111	AUSTIN MORRIS J4, 250 JU, petrol '67/'74
 Ref. PN 6074	461-66 5507919 DD 13483	JOHN DEERE 3, 4 cyl.
 Ref. PN 6075	461-181 7971192 536146	ROVER Landrover Diesel Suffix «K» onwards
 Ref. PN 6076	IMSA AK 0620101 994102	IMSA Mot. Perkins 4.99 y 4.108

Le ns. pompe non sono originali, ma con queste perfettamente intercambiabili. I numeri di riferimento originali hanno semplice valore indicativo.

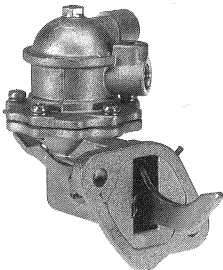
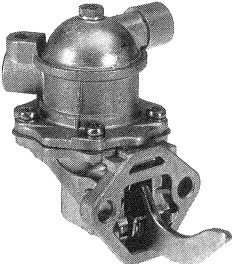
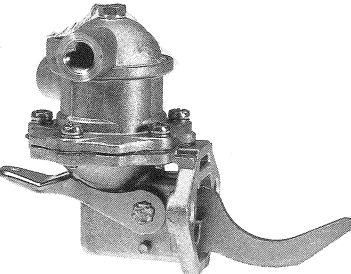
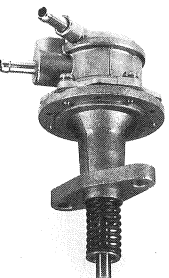
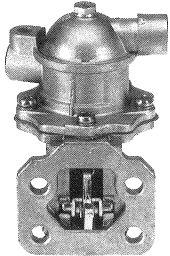
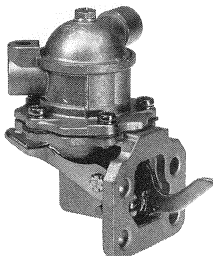
	N. Originale O.E.M.	Applicazione
 Ref. PN 6077	7950108	TR 2 4A mot. Perkins
 Ref. PN 6078	7950446 549761 461.113	ROVER Landrover 88,109 2 1/4 lit. petrol
 Ref. PN 6081	461-132 7950765 D 34167 2641375	ATKINSON L 1266 PT (Perkins 6.354) PERKINS 6/354 Atkinson L 1266 PT 1965 → 6/354 Dodge D 406, D 407, 6, 7, 8 ton 1965 → TALBOT (CHRYSLER) D 406 6 & 7 ton Perkins 6/354 1965 → D 407 7 & 8 ton Perkins 6/354 1965 →
 Ref. PN 6082	461-54 5506951 816045	BEDFORD Bedford Blitz 2100 G.M. Diesel 1978 → CF Van G.M. Diesel 1978 → OPEL Ascona 2000 Diesel 1979-81 Rekord D Diesel Rekord E Diesel 9/1977 →
 Ref. PN 6083	461-251 7990114 79064077 2641709	TALBOT (CHRYSLER) Commando 100 Ser-RG. Perkins 4/236 1974 → KC Walk Thru Perkins 4/236 Eng. 236U5670 → 1974 → KC Walk Thru Perkins 4/236 Eng. 236U5670 → 1967 →
 Ref. PN 6084	461-259 7990178 2641711	LANDINI Crawler Tractors 6500 Perkins 4/236 Wheel Tractors 6400 Perkins 4/236 Wheel Tractors 6500 MK II, 6500 MK II 4 RM Perkins 4/236 Wheel Tractors 7500, 7500 4 RM Perkins 4/236 Wheel Tractors 8500, 8500 4 RM Perkins 4/248 MASSEY FERGUSON 185/188 Eng. 248UA71961 → Perkins 4/248

Le ns. pompe non sono originali, ma con queste perfettamente intercambiabili. I numeri di riferimento originali hanno semplice valore indicativo.

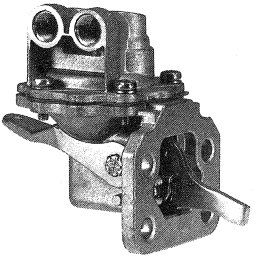
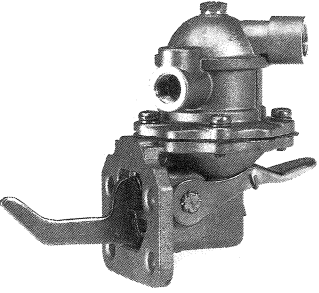
	N. Originale O.E.M.	Applicazione
 <p>Ref. PN 6085</p>	461-229 7990001 75065658 2641702	ALFA ROMEO Giulia Diesel (Perkins 4.108) BEDFORD CF Van Perkins 4/108 1974 → MOSKVITCH (URSS) 1700 Diesel Perkins 4/108 1978 → PERKINS A 4/108 1969 → TALBOT (CHRYSLER) PB Van Perkins 4/108 Eng. 108U46251 →
 <p>Ref. PN 6086</p>	461-310 25061593 264.1720	AVELING BARFORD VSI Road Roller, Vibratory Roller 6.354.4 Perkins BROYT X20, X21 Excavator 6.354.4 Perkins CHRYSLER Dodge 100 Series 6.354.4 Perkins COLES CRANES R270 Mobile Crane 6.354.4 Perkins COMPAIR CV 250 Portable Compressor 6.354.4 Perkins COMPAIR Compressor 6.354.4 Perkins CONSOLIDATED PNEUMATIC 250 CFM Compressor 6.354.4 Perkins COVENTRY CLIMAX DA 7/8 6.354.4 Perkins DALE ELECTRIC Generator Set 6.354.4 Perkins DRONNINGBORG SP Combine 6.354.4 Perkins HESTAIR DENNIS Delta 1616 Truck 6.354.4 Perkins HY-MAC 890 Excavator 6.354.4 Perkins HYDROMAC H115 Excavator, Hydraulic Excavators 6.354.4 Perkins HYSTER Fork Truck H 150 - 275 - 300 - 350 H 6.354.4 Perkins J.C.B. 808 Crawler Tractor 6.354.4 Perkins LANCER BOSS 700 FLT 6.354.4 Perkins LANDINI 10.500 6.354.4 Perkins, 13.500 AT 6.354.4 Perkins 12500, 12550 4 RM, 14500, 14500 4 RM 6.354.4 Perkins R 9500 MK II, R 9500 MK II 4 RM 6.354.4 Perkins MF 1100, MF 1134, 14500 Tractor 6.354.4 Perkins LAVERDA Combine 6.372.4 Perkins LEYLAND Boxer BX18TF, BX19TA, BX19TF 6.354.4 Perkins MASSEY FERGUSON MF 1250 MF 2620, MF 2640, MF 2680 Tractor 6.354.4 Perkins MF 2720 Tractor 6.354.4 Perkins MF 530 Combine, RX85 Tractor 6.354.4 Perkins MF HANOMAG 33C Shovel Loader 6.354.4 Perkins MUIRHILL 4 Wheel-Drive Agric Tractor 6.354.4 Perkins SEDDON ATKINSON Municipal Vehicle 6.354.4 Perkins SEDDON ATKINSON 200 Series Export 6.354.4 Perkins SPERRY NEW HOLLAND S/Propelled Bale Wagon 6.354.4 Perkins WEATHERHILL Shovel Loader 6.354.4 Perkins

Le ns. pompe non sono originali, ma con queste perfettamente intercambiabili. I numeri di riferimento originali hanno semplice valore indicativo.

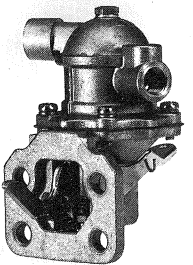
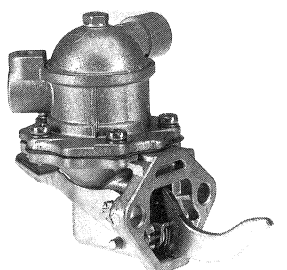
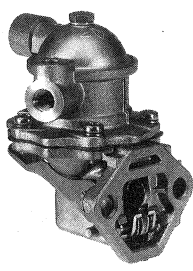
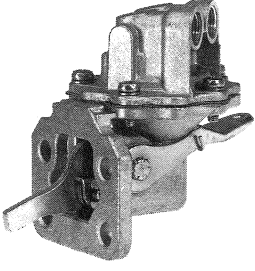
	N. Originale O.E.M.	Applicazione
 <p>Ref. PN 6087</p>	264.1725	PERKINS
 <p>Ref. PN 6089</p>	ETC 4303 1.518.019	LAND ROVER Rover 2400 - SD Turbo (VM) VM Mot. HR 388/92 H-HT HR 492-HT Leyland
 <p>Ref. PN 6090</p>	276.6585.30	LOMBARDINI LDA 672 - 673 - 832 - 833
 <p>Ref. PN 6091</p>	IMSA AK 0870101	FIAT SUPERMIRAFIORI Mot. Perkins 4.99 - 4.108

Le ns. pompe non sono originali, ma con queste perfettamente intercambiabili. I numeri di riferimento originali hanno semplice valore indicativo.

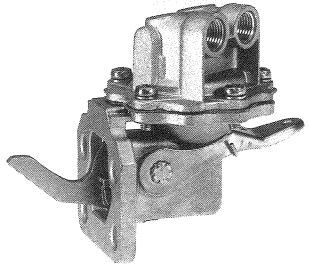
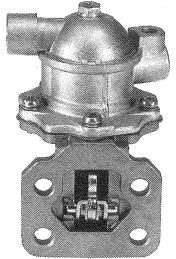
	N. Originale O.E.M.	Applicazione
	Ref. PN 6092 461-312 25061608 264.1712 9315.1069	ATLAS COPCO XA60 Compressor D3.152 Perkins BOLINDER MUNKTELL T430 Agric. Tractor D3.152 Perkins BROOME & WADE Compressor CAI Standard Plant/Compressor CAIS Silenced Plant D3.152 Perkins CONSOLIDATED PNEUMATIC D3.152 Perkins DALE ELECTRIC Gen. Set D3.152 Perkins EICHER 3155/3255/3256 Tractors D3.152 Perkins HYDROVANE COMPRESSORS 85 CFM Compressor D3.152 Perkins HYSTER Fork Truck S30/40C FLT D3.152 Perkins INGERSOLL RAND P140 WP Air Compressor D3.152 Perkins 85 CFM Compressor D3.152 Perkins JOHNSTON BROS Road Sweeper D3.152 Perkins LANDINI MF 244 Crawler Tractor D3.152 Perkins TL 19C, TL 21C Crawler Tractor D3.152 Perkins LEYLAND 245 Quiet Cab Tractor D3.152 Perkins LINDNER Tractor, Transporter, 520S Tractor D3.152 Perkins MASSEY FERGUSON 122 Tractor 3.152 Eng. O.E. Nr. 2641712 I.C.M. Aprilia MF 100C Crawler Tractor D3.152 Perkins MF 133/135 Vineyard Tractor D3.152 Perkins MF 135, MF 135/2135 Tractor D3.152 Perkins MF 148 Tractor D3.152 Perkins MF 2203-7, MF 2205-7 Ind. Tractor D3.152 Perkins MF 235, MF 245, MF 255 Tractor D3.152 Perkins MF 550 Tractor D3.152 Perkins PERKINS D3.152 General Industrial
	Ref. PN 6093 2.4519.230.0 2.4519.220.0	HURLIMANN (CH) H 6160 (c/mot. Same) LAMBORGHINI Tr. 1056 c/mot. Same 6 cyl. 1979 → SAME Tr. Bufalo 130 6 cyl. 1979 → Tr. Drago 120 6 cyl. 1979 → Tr. Panther 90 5 cyl. 1979 → Tr. Tiger 100 5 cyl. 1979 →

Le ns. pompe non sono originali, ma con queste perfettamente intercambiabili. I numeri di riferimento originali hanno semplice valore indicativo.

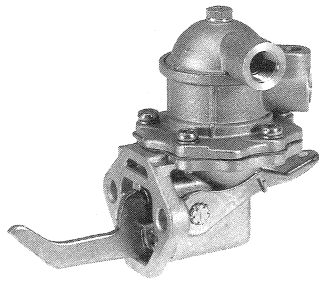
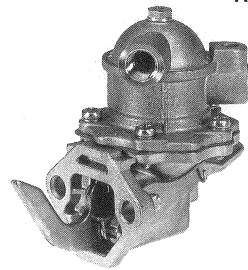
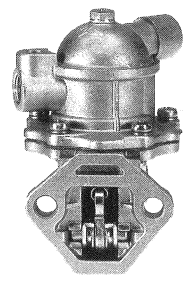
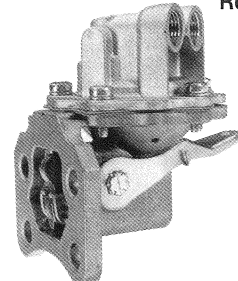
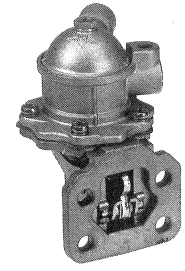
	N. Originale O.E.M.	Applicazione
	Ref. PN 6094 461-165 7971038 7950540 12641406 2641406 6616798	AVELING BARFORD Road Roller GB5 Perkins 3/152 BOLINDER MUNKTELL Terrier Tractor Perkins 3/152 TA HYSTER Fork Truck S30/40C Perkins 3/152 LANDINI 4000, 5000 Perkins 3/152 MARSHALL Road Roller Perkins D3/152 MASSEY FERGUSON Model 135 Tractor Perkins A3/152 1965 → Model 203 Perkins 3A/152 1960 → Model 205 Perkins 3A/152 1960 → 135 Tractor → Eng. 152UA38570D Perkins 3/152 1965 → PERKINS 3A/152 Bolinder Munktell Terrier Tractor 1965 → 3A/152 Massey Ferguson 135 Tractor
	Ref. PN 6095 461-287 25061588 7990486	SAVIEM SM5, SM6, SM7, SM8, S9 597 6 cyl.
	Ref. PN 6096 602-40480	LISTER
	Ref. PN 6097 201.39670 201.45340	LISTER
	Ref. PN 6098 602.37260	LISTER

Le ns. pompe non sono originali, ma con queste perfettamente intercambiabili. I numeri di riferimento originali hanno semplice valore indicativo.

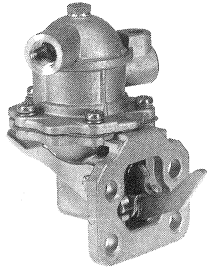
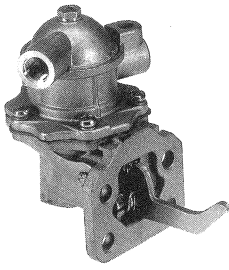
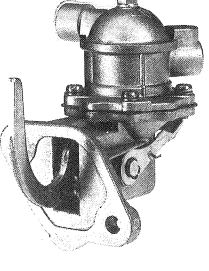
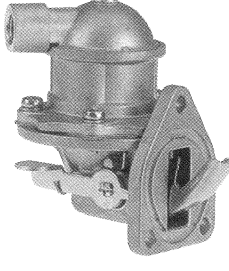
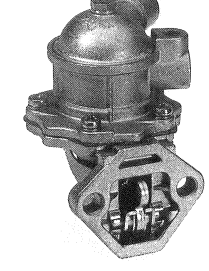
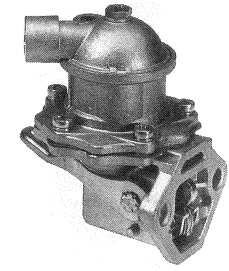
	N. Originale O.E.M.	Applicazione
 Ref. PN 6099	461-303 7990347 2641706	VOLKSWAGEN LT28, LT31, LT31 Perkins 4/165 Diesel
 Ref. PN 6100	461-258 25061561	CHRYSLER Commer Commando 6.354, 6.354.2, T6.354.3 Perkins VA Truck 8/12 Ton 6.354 Perkins Eng. 354U191486 → VB Truck 8/12 Ton Perkins 6.354 Eng. 354U191486 → VC Truck 8/12 Ton 6.354 Perkins Eng. 354U191486 → Dodge Commando 6.354, 6.354.2, T6.354.3 Perkins Dodge D-K500 T6.354.3 Perkins MASSEY FERGUSON MF 1114, MF 1134
 Ref. PN 6102	461.403	AUSTIN London Taxi (FX4)
 Ref. PN 6103	7.15252.50 213.4511 KZ 0150.17 210.0087 UC 0150.17	K H D F3L 812 D 1964 → F3L 912/912 W 1964 → F4L 812 D 1964 → F4L 912/912 W 1964 → F5L 912/912 W 1964 → F6L 812 D 1964 → F6L 912/912 W 1964 →
 Ref. PN 6104	351.12150	LISTER
 Ref. PN 6105	351.12151	LISTER

Le ns. pompe non sono originali, ma con queste perfettamente intercambiabili. I numeri di riferimento originali hanno semplice valore indicativo.

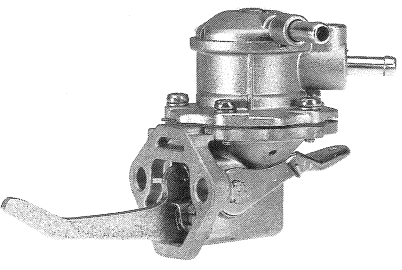
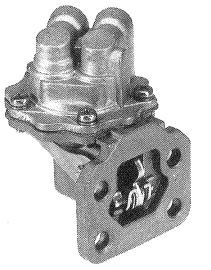
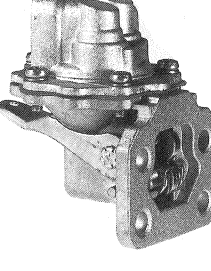
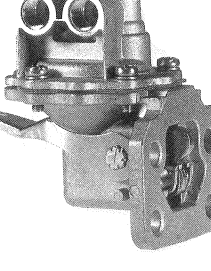
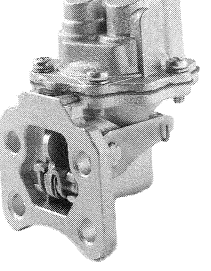
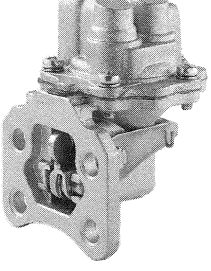
	N. Originale O.E.M.	Applicazione
 Ref. PN 6110	461.42 25061434	BERLIET mot. 420-30
 Ref. PN 6111	296531	LISTER
 Ref. PN 6112	201.39672	LISTER
 Ref. PN 6113	201.39671	LISTER
 Ref. PN 6116	201.45341	LISTER
 Ref. PN 6117	201.45342	LISTER

Le ns. pompe non sono originali, ma con queste perfettamente intercambiabili. I numeri di riferimento originali hanno semplice valore indicativo.

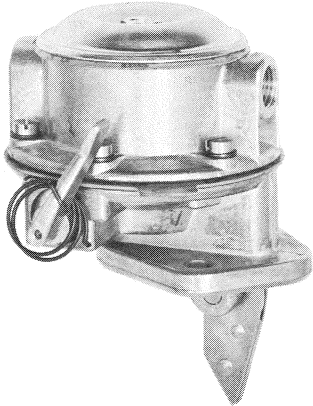
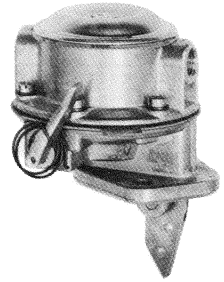
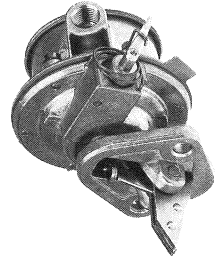
	N. Originale O.E.M.	Applicazione
 <p>Ref. PN 6500</p>	461-179 7971183 7971029 12A1259 831149 831149 A A 500 360 A502983 D 33 858 510E 9350 2641469	<p>A E C Guy 470 Eng. Simms P4/6731</p> <p>ALBION K & M 4 & cyl. Diesel Trucks Leyland 0E370 & 0E400 1961-65</p> <p>BEDFORD TK Truck EOM, EON, EOQ, EOR, EOT, EOY, HRX3 370 & 400 cu. in Diesel VA Coach Chassis 400 cu. in Diesel</p> <p>C.A.V. DIESEL INJECTORS Leyland 0E370 & 0E400 Eng. Albion Truck</p> <p>FORD COMMERCIAL D 1000 Series V8.511 cu. in Diesel senza recirculating fuel system D 1000 Truck 511 cu. 1967 →</p> <p>FORD INDUSTRIAL ENGINES 4 cyl. + Simms Units P4632, P4633, P4679, P4685, P4686 6 cyl. + Simms Units P4594, P4635, P4636, P4664, P4684, P4687</p> <p>FORD TRACTORS Super Dexta Light 1962-66 Super Major 5000 1964 → 3000, 5000-8000, 9000 → 1/1974</p> <p>LEYLAND Bus Comet 370 Eng. Simms Unit P4606/1 Perkins V8.510, V8.540: H.E. Simms P4614</p> <p>BLUELINE TRUCKS 0E370, 400 Simms Inj. 1966 → 0E370, 400 CAV Equipment 370 Eng. Simms Units P4657, P4621 & P4606 400 Eng. Simms Units P4637, P4572 & P4613 400 Eng. Veh. Simms P4654 & P4692 475 Eng. Comet</p> <p>TALBOT (CHRYSLER) Dodge D407 7 & 8</p>
 <p>Ref. PN 6501</p>	461-161 7971025 7950732 7950948 05058066 2641465	<p>ALLIS CHALMERS A Cleaner Harvester Perkins 4/236 TA</p> <p>BARBER-GREEN SA 40 Paver</p> <p>MASSEY FERGUSON DX 65 Perkins 4 A/236</p>
 <p>Ref. PN 6502</p>	<p>AC-VP 7971236 AC-VP 7950788 7971030</p> <p>Simms A 503557 501352</p>	<p>FORD COMMERCIAL 530E (+) Simms Unit P4672 1962 →</p> <p>INTERNATIONAL HARVESTER BD 281 Diesel Engine BD 281 con Simms injection BTD 6-8 con Simms injection B 450 con Simms injection B 450 Wheel Tractor B 604 - P 4610 TD 6 Crawler Tractor</p> <p>SIMMS 3 - 4 - 5 - 6 cyl. Cambox</p>

Le ns. pompe non sono originali, ma con queste perfettamente intercambiabili. I numeri di riferimento originali hanno semplice valore indicativo.

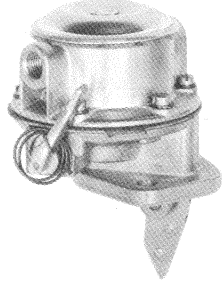
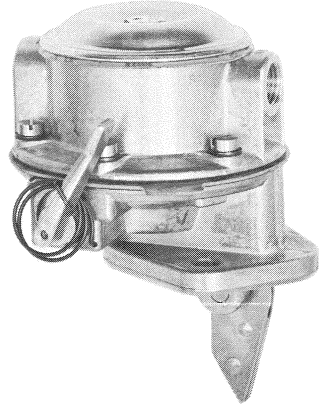
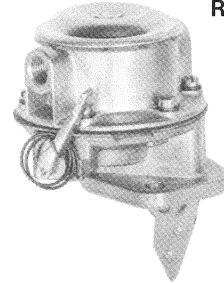
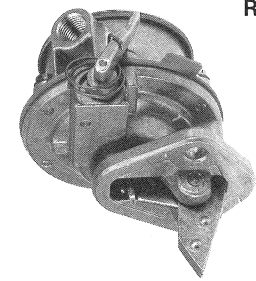
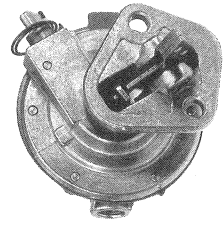
	N. Originale O.E.M.	Applicazione
 <p>Ref. PN 6503</p>	461-213 7971392 A504828 66013740 2641473	<p>HAULAMATIC Dump Truck 615 Perkins V8.540</p> <p>LEYLAND Perkins V8.510, V8.540: Boxer - BX1425 Mastiff & Super Mastiff</p> <p>PERKINS V8.540 Talbot 1974 →</p> <p>TALBOT Commando 100 Ser. RG Perkins V8.540 1974 →</p>
 <p>Ref. PN 6504</p>	461-217 7971399 LM831637 A 504827	<p>BRISTOL Bristol LH Series 401, 410</p> <p>LEYLAND Bus Clydesdale ECD 23, ECD 27 401 Bus Leyland National 502 Viking EVK 55 401</p> <p>BLUELINE TRUCKS Bison 500 1970 → Buffalo 500 Chieftain 410 Turbo Clydesdale 301 Lynx 26T, 28T 500 1970 → Octopus 30T 502 Reiver - 401, 410 500 Eng. 1971 →</p> <p>SHELVOKE & DREWRY Intapak, PT Revepak 401 or 410 Leyland</p> <p>SISU BX84B0 City Coach 500 Turbo Leyland</p>
 <p>Ref. PN 6505</p>	461-220 7971405 A505166 75060559 2641507	<p>TALBOT (CHRYSLER) D-K500 Perkins V8.510, V8.540 1976 →</p> <p>PERKINS V8.510, V8.540 Dodge 1976 →</p>
 <p>Ref. PN 6506</p>	<p>AC-VP 7990439 Perkins 2641477 CAV 508203</p>	<p>PERKINS Motore 4/236</p>
 <p>Ref. PN 6507</p>	<p>AC-VP 7971135 Perkins 2641467</p>	<p>PERKINS Motore 4/236</p>

Le ns. pompe non sono originali, ma con queste perfettamente intercambiabili. I numeri di riferimento originali hanno semplice valore indicativo.

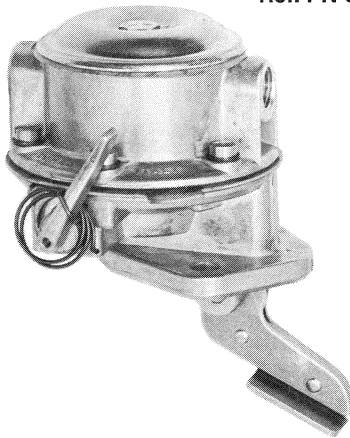
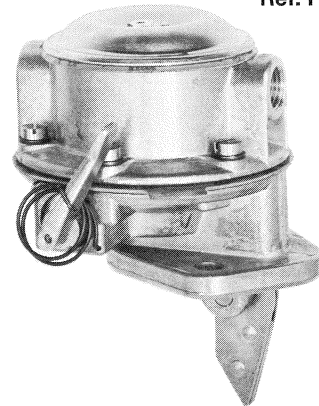
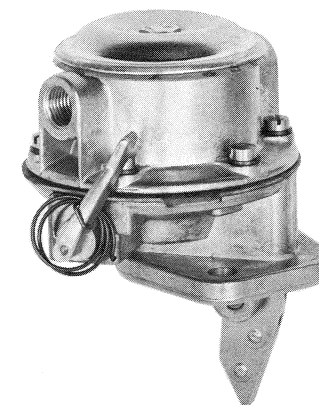
	N. Originale O.E.M.	Applicazione
	Ref. PN 6508 461-276 7990361 7971160 683F9350 AB	COLES Cranes Hydra 6 ton → 10 ton Ford 2713 E → 10/1973 FORD COMMERCIAL D/N Series Diesel ad eccez. cold start 4200, 6000, 6200, DA10-DA21, DT 17/20 D1000 Series 360 cu. in Turbo Diesel senza cold start 1967 → D Truck Diesel 1965 → K Truck Diesel 1965 → R Series 360 cu. & 380 cu. 1965 → 2715E Eng. 6 cyl. 135 HP FORD INDUSTRIAL ENGINES 2700 Series - senza cold start 254, 380 cu. 1965-73
	Ref. PN 6509 461-314 7990449 A512546/2 4880294	C.A.V. DIESEL INJECTORS Equipment Leyland OE 370, 400 LEYLAND - Redline Trucks 6/98 Turbocharged Diesel: Boxer - BX 1300, BX 1425, BX 20F 1973 → BLUELINE TRUCKS 0400 Eng. CAV Equipment VOLVO Loaders LM621, LM641 1979 → Loaders LM4300 1979 →
	Ref. PN 6510 461-330 93151104 A 514294/2	LEYLAND Perkins V8.510, V8.540: Mastiff 1972 → PERKINS V8.510 Marine TALBOT (CHRYSLER) Perkins V8.540 1974 → Commando 100 Ser. RG Perkins V8.540 1974 →

Tavole comparative rif. PN con rif. altri costruttori
Comparative tables of PN ref. to ref. of others manufacturers
Tableaux de comparaison ref. PN avec ref. d'autres fabricants

REF. BCD	REF. PIENNE	REF. AC DELCO	REF. BCD	REF. PIENNE	REF. AC DELCO
1522	6016	—	1833	6017	—
1530/1	6078	461.113	1834	6081	461.132
1533/2a	6500	461.179	1837	6042	—
1535/1	6037	461.170/171	1838/1	6043	—
1544	6070	461.176	1839/1	6030	—
1549	6053	461.159	1841	6505	461.220
1552	6500	461.179	1856/1	6083	461.251
1640	6018	—	1859/1	6061	461.167
1647/1	6019	461.110	1860	6068	—
1659/1	6020	—	1861	6066	—
1660/1	6056	461.108	1863	6063	461.193
1662	6103	—	1870	6062	461.147
1666	6012	—	1871	6064	—
1678	6065	461.116/137	1873/1	6084	461.259
1681	6040	—	1877	6070	461.176
1686	6508	461.276	1881	6024	461.148
1687	6067	461.133/135	1886/1	6036	461.279
1692/1	6015	—	1899/1	6013	—
1693	6501	461.161	1902	6060	461.240
1695/1	6094	461.165	1905	6059	461.115
1702/1	6000	—	1910/1	6033	—
1706/1	6022	—	1911/1	6045	—
1730/1	6023	461.109	1915	6039	461.352
1721	6034	—	1920	6069	—
1751	6047	—	1927 (276.6585.30)	6090	—
1752	6048	461.175	1927 (276.6585.11)	6001	—
1755	6049	—	1928	6007	—
1756	6050	461.123	1929	6044	—
1757	6075	461.181	1930	6093	—
1758	6051	461.205	1941	6099	461.303
1768	6014	—	1942	6086	461.310
1770	6038	—	1943	6074	461.66
1774/1	6025	461.233	1946	6039	461.352
1779	6052	461.246	1947	6003	—
1780	6009	—	1948	6004	—
1796	6503	461.213	1949	6006	—
1797	6504	461.217	1959	6066	—
1808	6072	461.114	1961	6082	461.54
1809/1	6058	—	1971	6089	—
1810/1	6057	461.204	1973	6509	461.314
1812	6046	461.184	1975	6510	461.330
1820	6069	—	1977	6041	—
1824	6041	—	1987	6092	461.312
1825	6031	—	1988	6096	—
1826	6002	—			
1829/1	6085	461.229			

Tavole comparative rif. PN con rif. altri costruttori
Comparative tables of PN ref. to ref. of others manufacturers
Tableaux de comparaison ref. PN avec ref. d'autres fabricants

REF. AC DELCO	REF. PIENNE	REF. BCD	REF. AC DELCO	REF. PIENNE	REF. BCD
461.42	6110	—	461.184	6046	1812
461.54	6082	1961	461.193	6063	1863
461.66	6074	1943	461.204	6057	1810/1
461.67	6067	1687	461.205	6051	1758
461.108	6056	1660/1	461.213	6503	1796
461.109	6023	1730/1	461.217	6504	1797
461.110	6019	1647/1	461.220	6505	1841
461.113	6078	1530/1	461.229	6085	1829/1
461.114	6072	1808	461.233	6025	1774/1
461.115	6059	1905	461.240	6060	1902
461.116	6065	1678	461.246	6052	1779
461.123	6050	1756	461.251	6083	1856/1
461.132	6081	1834	461.258	6100	—
461.133/135	6067	1687	461.259	6084	1873/1
461.137	6065	1678	461.264	6087	—
461.147	6062	1870	461.276	6508	1686
461.148	6024	1881	461.279	6036	1886/1
461.159	6053	1549	461.287	6095	—
461.161	6501	1693	461.303	6099	1941
461.165	6094	1695/1	461.310	6086	1942
461.167	6061	1859/1	461.312	6092	1987
461.170	6037	1535/1	461.314	6509	1973
461.175	6048	1752	461.330	6510	1975
461.176	6070	1544/1877	461.352	6039	1946/1915
461.179	6500	1533/2a-1552	461.403	6102	—
461.181	6075	1757			

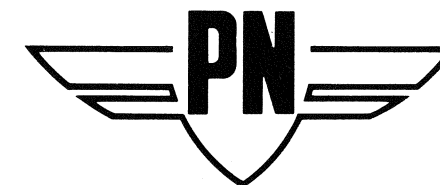

MADE IN ITALY

CONDIZIONI GENERALI DI VENDITA

Spedizioni. - Il trasporto della merce è a rischio e pericolo del committente, non rispondiamo di eventuali ritardi della spedizione dopo la consegna della merce al vettore, in mancanza di indicazioni esatte le spedizioni verranno eseguite con il mezzo da noi ritenuto più conveniente.

Sostituzioni. - Verrà gratuitamente sostituito quel materiale che, rinviato franco nostro domicilio, venga da noi ritenuto difettoso. Le nostre garanzie sono limitate alla sostituzione, la quale non dà diritto ad alcun indennizzo di danno derivante dalla rottura dei pezzi.

Reclami. - Salvo casi da noi riconosciuti non saranno presi in considerazione i reclami che ci pervenissero oltre 30 giorni dal ricevimento della merce.

Contestazioni. - Per qualsiasi controversia sarà competente il Foro di Torino.

QUESTO CATALOGO ANNULLA TUTTI I PRECEDENTI

CONDITIONS GENERALES DE VENTE

Expédition. - Le transport de la marchandise doit être considéré aux risques et périls de l'acheteur. Nous ne sommes pas responsables d'éventuels retards dans l'expédition après la livraison de la marchandise au transporteur. En manque d'indications particulières l'expédition sera faite par le moyen que nous considérons le plus convenable.

Remplacements. - Nous pourrions au remplacement gratuit du matériel que, après la livraison à domicile, sera considéré défectueux par nous. Nos garanties sont limitées au remplacement, sans cependant reconnaître d'indemnisations pour de dommages causés par la rupture des pièces.

Réclamations. - Sauf pour les cas reconnus par nous, les réclamations qui dussent arriver après 30 jours de la réception de la marchandise ne seront pas prises en considération.

Contestations. - Toute différend sera soumise au Tribunal à Turin.

CE CATALOGUE ANNULE TOUS LES CATALOGUES PRECEDENTS

GENERAL CONDITIONS OF SALES

Shipments. - The transport of the goods is at risk and peril of the addressee, we do not respond for possible delays of transport after the delivery of the goods to the carrier; in default of precise instructions, shipments will be effected by the means that we deem the most adequate.

Replacements. - We shall replace free of charge that material which, returned free to our works, we will have recognized as defective. Our warranties are limited to the replacement, which does not entitle to any compensation of damage deriving from the failure of parts.

Claims. - Apart from cases recognized by ourselves, we shall not take into consideration any claim that is received when more than 30 days have elapsed since the receipt of the goods.

Disputes. - The law-court of Torino will be qualified for any controversy whatever.

THIS CATALOGUE SUPERSEDES ALL THE PREVIOUS ONES

PIENNE s.r.l.

VIA CRISTALLIERA, 21 - 10139 TORINO - TEL. 76.16.13 - 76.14.95 - TLX 225537 I